

Confidential



basic education

Department:
Basic Education
REPUBLIC OF SOUTH AFRICA

**NATIONAL
SENIOR CERTIFICATE**

GRADE 12

TECHNICAL SCIENCES P1

NOVEMBER 2025

MARKS: 150

TIME: 3 hours

This question paper consists of 15 pages and 3 data sheets.

INSTRUCTIONS AND INFORMATION

1. Write your centre number and examination number in the appropriate spaces on the ANSWER BOOK.
2. This question paper consists of TEN questions. Answer ALL the questions in the ANSWER BOOK.
3. Start EACH question on a NEW page in the ANSWER BOOK.
4. Number the answers correctly according to the numbering system used in this question paper.
5. Leave ONE line between two subquestions, e.g. between QUESTION 2.1 and QUESTION 2.2.
6. You may use a non-programmable calculator.
7. You may use appropriate mathematical instruments.
8. You are advised to use the attached DATA SHEETS.
9. Show ALL formulae and substitutions in ALL calculations.
10. Round off your FINAL numerical answers to a minimum of TWO decimal places.
11. Give brief motivations, discussions, etc. where required.
12. Write neatly and legibly.

QUESTION 1: MULTIPLE-CHOICE QUESTIONS

Various options are provided as possible answers to the following questions. Choose the answer and write only the letter (A–D) next to the question numbers (1.1 to 1.10) in the ANSWER BOOK, e.g. 1.11 D.

1.1 How does the coefficient of static friction (μ_s) compare to that of kinetic friction (μ_k) when the same object moves on the same surface?

- A Equal to
- B Smaller than
- C Greater than
- D None of the above-mentioned

(2)

1.2 A 2 kg mass piece is placed on a stationary 2 kg trolley, which is on a frictionless horizontal surface. When a force **F** is applied to the trolley, it has an acceleration **a**, as shown in Diagram 1 below. An additional 1 kg mass piece is then placed on the trolley and the same force **F** is applied, as shown in Diagram 2.

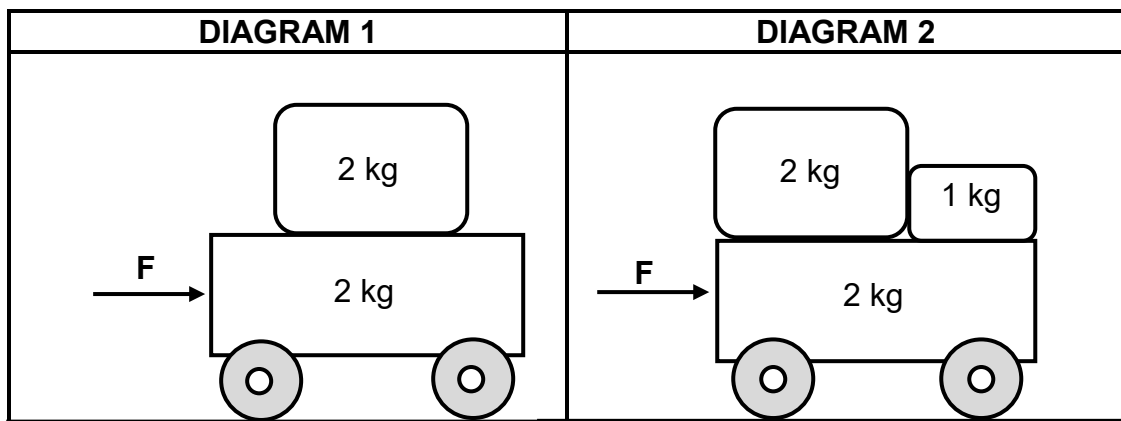

What is the acceleration of the trolley in Diagram 2?

- A $\frac{1}{4}a$
- B $\frac{2}{3}a$
- C $\frac{4}{5}a$
- D $\frac{5}{4}a$

(2)

- 1.3 Two blocks, **P** and **Q**, of masses **m** and **2m** respectively, are resting on a frictionless horizontal surface. They are connected by a piece of rubber band. The blocks are pulled apart, stretching the rubber band and then released simultaneously.



Which ONE of the following statements is TRUE regarding the speed of the blocks just before they collide with each other?

- A **P** has half the speed of **Q**.
- B **P** has twice the speed of **Q**.
- C **P** and **Q** have the same speed.
- D **P** has three times the speed of **Q**. (2)
- 1.4 How much horsepower is 746 watts?
- A 1
- B 10
- C 100
- D 1 000 (2)
- 1.5 Which ONE of the following can be used to determine the gravitational potential energy of an object?
- A Mass of the object, its velocity and its position above the surface of the earth
- B Mass of the object, its velocity and its position beneath the surface of the earth
- C Mass of the object, gravitational acceleration and its position above the surface of the earth
- D Mass of the object, gravitational acceleration and its position beneath the surface of the earth (2)

1.6 ... is the property of a body whereby the body regains its original shape and size when a deforming force is removed.

A Inertia

B Elasticity

C Stress

D Strain

(2)

1.7 Which ONE of the following equations for hydraulic lifts is INCORRECT?

A $F_1A_2 = F_2A_1$

B $F_1A_1 = F_2A_2$

C $\frac{F_1}{A_1} = \frac{F_2}{A_2}$

D $\frac{A_1}{F_1} = \frac{A_2}{F_2}$

(2)

1.8 An object is placed between **F** and a concave lens, as shown in the diagram below.

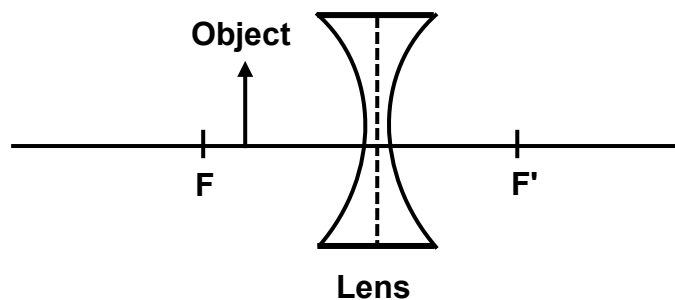

The image formed is ...

A virtual, upright and larger than the object.

B virtual, upright and smaller than the object.

C real, inverted and smaller than the object.

D real, inverted and has the same size as the object.

(2)

1.9 Which ONE of the following is the CORRECT equivalent SI unit for one tesla?

- A $N \cdot m \cdot A^{-1}$
- B $V \cdot s \cdot m^{-1}$
- C $Wb \cdot m^{-2}$
- D $A \cdot m^2$

(2)

1.10 Which ONE of the following diagrams represents an AC generator?

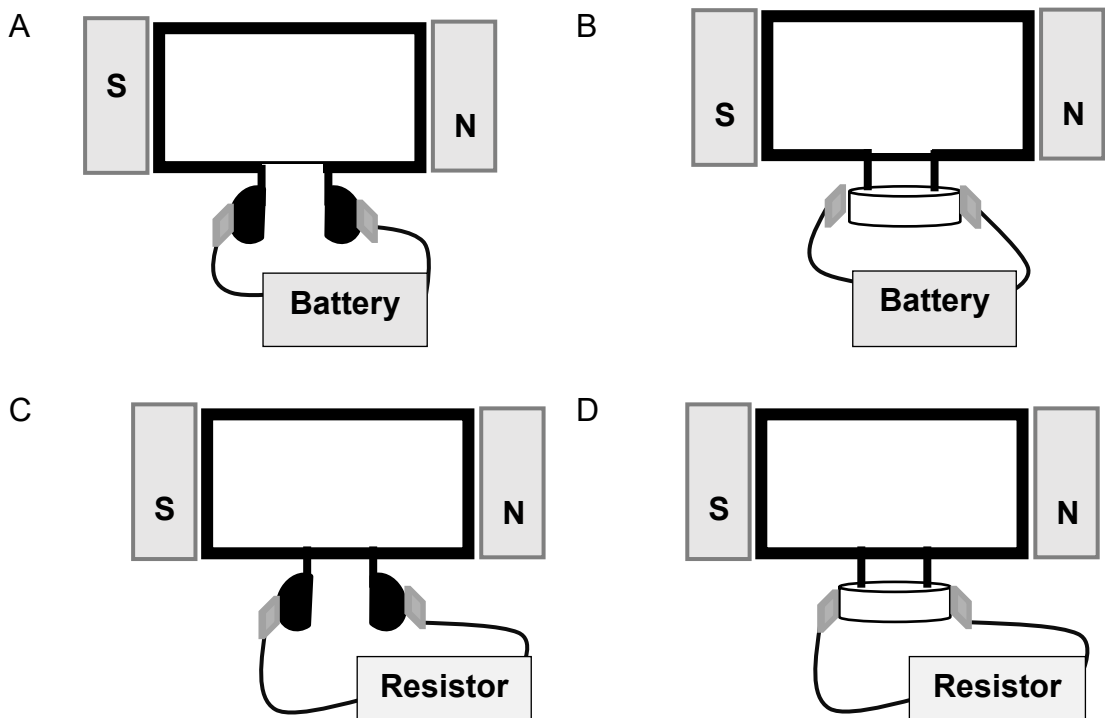

(2)
[20]

QUESTION 2 (Start on a new page.)

Two blocks of mass 9 kg and 18 kg, resting on a rough horizontal surface, are connected by a light inextensible string. When a force of 65 N is applied to the 18 kg block at an angle of 25° to the horizontal, the system accelerates to the right. The 9 kg block experiences a constant frictional force of 1,76 N. The coefficient of kinetic friction between each block and the surface is 0,02.

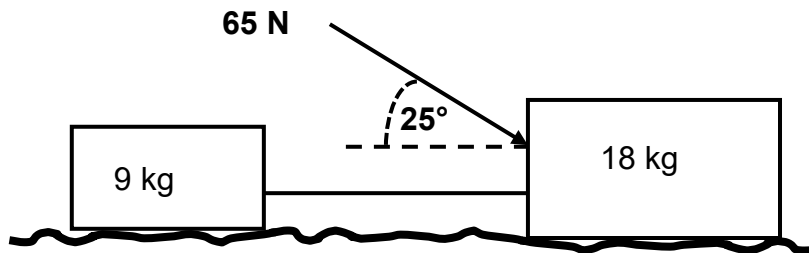

- 2.1 State *Newton's Second Law of Motion* in words. (2)
- 2.2 Draw a labelled free-body diagram of ALL the forces acting on the 18 kg block. (5)
- 2.3 Calculate the magnitude of the:
- 2.3.1 Normal force on the 18 kg block (3)
- 2.3.2 Kinetic frictional force of the 18 kg block (3)
- 2.3.3 Acceleration of the system (5)
- 2.4 The same force of 65 N is now applied at an angle of 0° on the same rough horizontal surface. How will the magnitude of the normal force be affected? Write down only INCREASES, DECREASES or REMAINS THE SAME. (1)

[19]

QUESTION 3 (Start on a new page.)

Car **A** of mass 1 500 kg travels at 30 m·s⁻¹ to the right and collides with car **B** of mass 1 800 kg, which is initially at rest. The velocity-time graph below (not drawn to scale) shows the motion of car **A** before, during and after the collision with car **B**. Ignore ALL effects of friction.

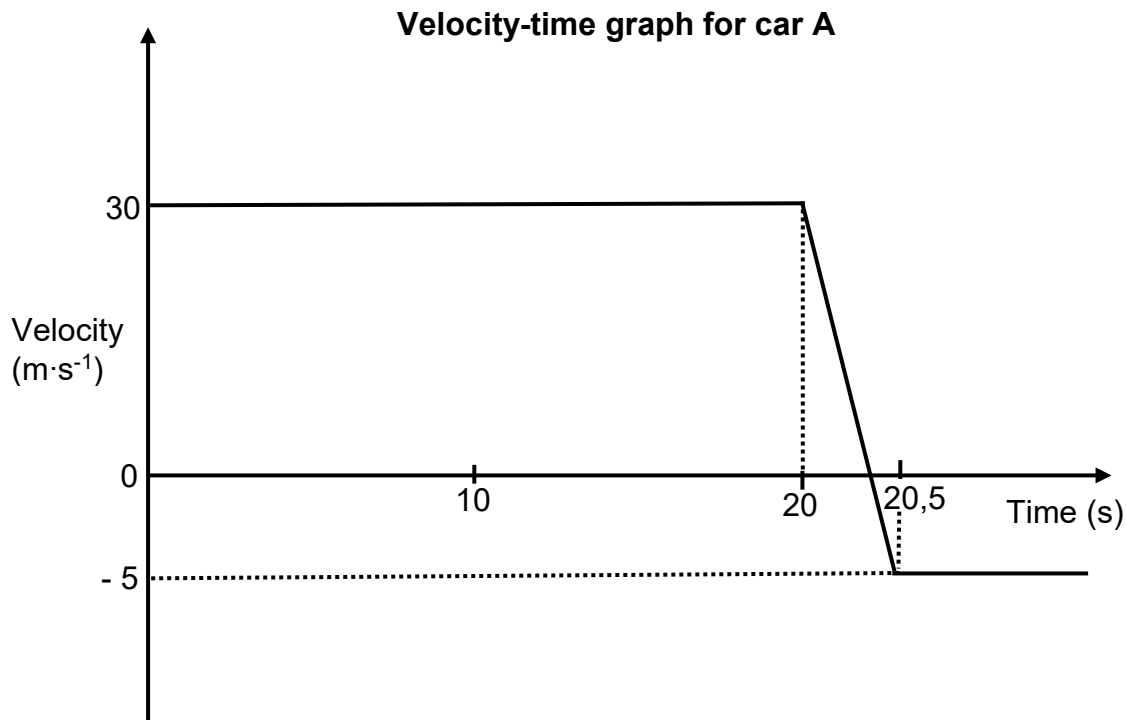

- 3.1 State the *principle of conservation of linear momentum* in words. (2)
- 3.2 Calculate the:
 - 3.2.1 Velocity of car **B** after the collision (4)
 - 3.2.2 Net force that car **A** exerts on car **B** during the collision (4)
- 3.3 Use a suitable calculation to determine whether the collision is ELASTIC or INELASTIC. (5)
- 3.4 Write down the magnitude of the force that car **B** will exert on car **A**. (1)
- 3.5 Name the law that was used in QUESTION 3.4. (1)
- 3.6 Write down ONE safety feature that is installed in modern cars to reduce the severity of injuries during a collision. (1)

[18]

QUESTION 4 (Start on a new page.)

A weightlifter pulls a 1 600 kg car over a distance of 100 m along a horizontal road. He applies a constant force of 460 N, which acts at an angle of 40° to the horizontal. The frictional force between the surface of the road and the tyres of the car is 325 N.

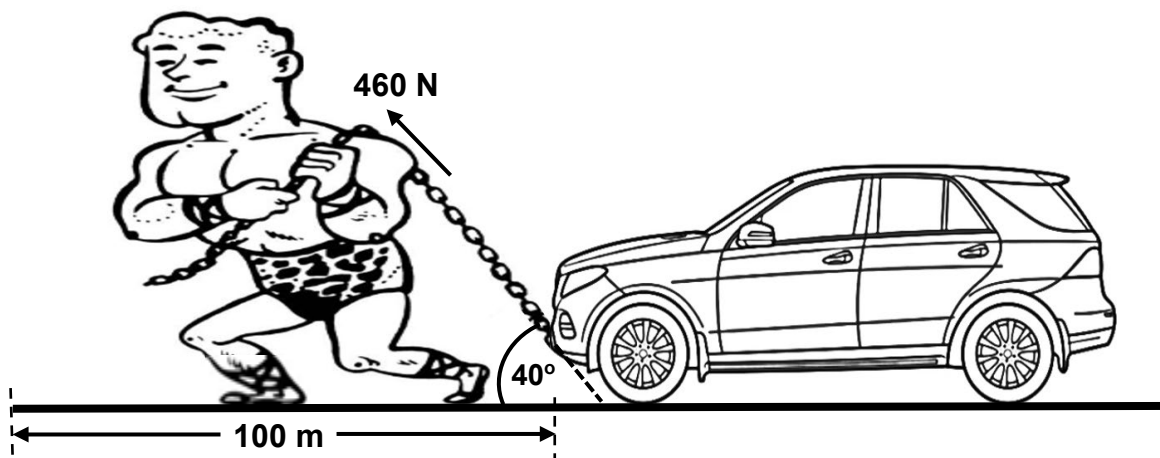

- 4.1 Define the term *isolated system*. (2)
- 4.2 Calculate the:
 - 4.2.1 Work done by the applied force acting on the car (3)
 - 4.2.2 Work done by the friction (2)
 - 4.2.3 Net work done (2)
- 4.3 A block of mass 5 kg slides from rest at point **A** to point **C** along a frictionless track, as shown in the diagram below.

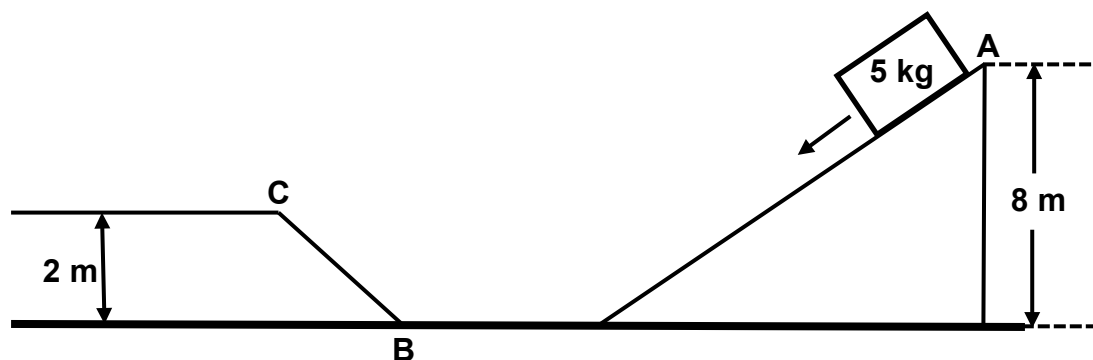

- 4.3.1 Is mechanical energy conserved as the block slides along the track? Write down only YES or NO. Briefly explain the answer. (3)
- Calculate the:
 - 4.3.2 Kinetic energy at point **B** (5)
 - 4.3.3 Speed of the block when it reaches point **C** (4)

[21]

QUESTION 5 (Start on a new page.)

- 5.1 Define *Young's modulus of elasticity*. (2)
- 5.2 A corroded section of a car door is removed and replaced with a piece of a metal sheet that is welded onto the door.
- 5.2.1 Should Young's modulus of elasticity of the metal sheet be different from or similar to that of the original material of the car door? Write down only DIFFERENT FROM or SIMILAR TO. (1)
- 5.2.2 Explain the answer to QUESTION 5.2.1. (2)
- 5.3 The stress and strain values for human bone are $1,6 \times 10^8$ Pa and $1,78 \times 10^{-2}$ respectively.
- Calculate the value of Young's modulus of elasticity of human bone when it is subjected to compression. (3)
- [8]**

QUESTION 6 (Start on a new page.)

Study the diagram of a hydraulic log splitter below and answer the questions that follow.

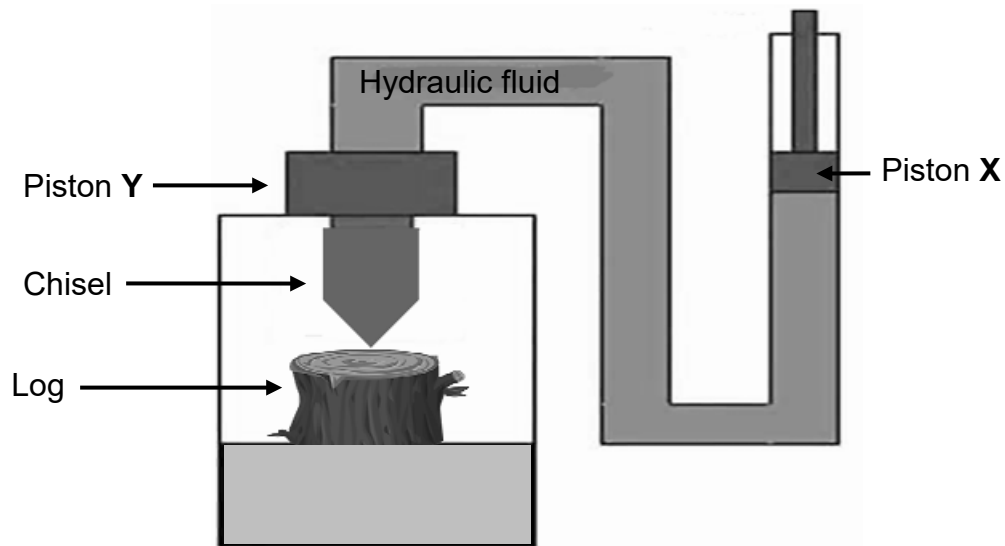

6.1 State *Pascal's law* in words. (2)

The pressure exerted by piston **X** is $2,67 \times 10^6$ Pa and its radius is 0,046 m. The area of piston **Y** is larger than that of piston **X**.

6.2 Calculate the force applied at piston **X**. (4)

6.3 How does the force exerted by the chisel on the wooden block compare to that exerted by piston **X**? Write down LESS THAN, EQUAL TO or GREATER THAN. (1)

6.4 The hydraulic log splitter is operated in a cold environment.

6.4.1 What type of hydraulic oil would be best in this environment? Write down OIL WITH LOWER VISCOSITY or OIL WITH HIGHER VISCOSITY. (1)

6.4.2 Give a reason for the answer to QUESTION 6.4.1. (2)

6.5 What would happen to the viscosity of the hydraulic oil when the machine is in operation? Write down only DECREASES, INCREASES or REMAINS THE SAME.

Briefly explain the answer. (3)
[13]

QUESTION 7 (Start on a new page.)

7.1 A student holds a sheet of paper with letters on it facing a plane mirror. The letters on the paper are shown below.

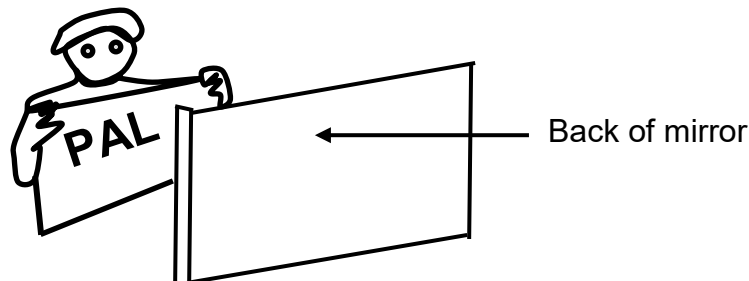

- 7.1.1 Define the term *reflection*. (2)
- 7.1.2 Write down the letters as they appear in the mirror. (2)
- 7.1.3 Write down TWO characteristics of the image that is formed in this mirror. (2)

7.2 The diagrams below show different phenomena that occur as a light ray passes from material **A** to material **B**, with different optical density. Material **A** is more optically dense than material **B**. The critical angle of material **A** is 47° .

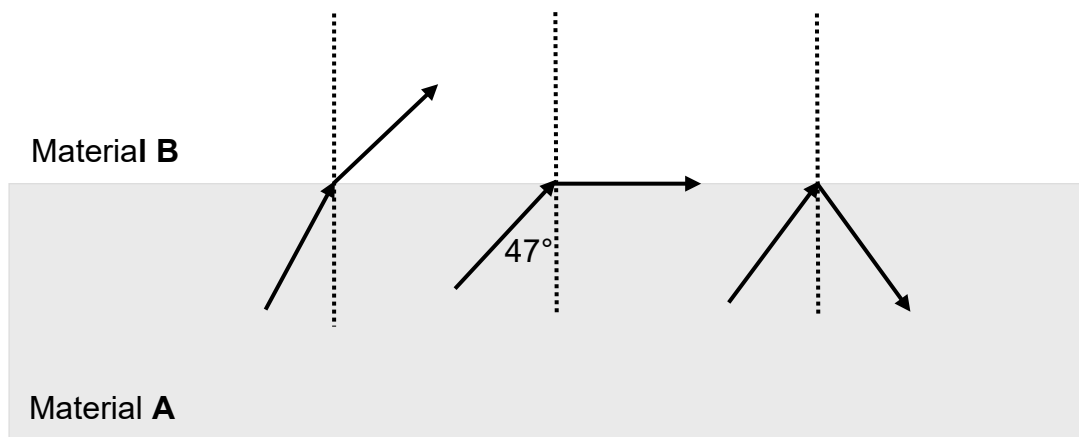

- 7.2.1 Define the term *critical angle*. (2)
- 7.2.2 Which range of angles will make it possible for total internal reflection to occur? (2)
- 7.3 How are electromagnetic waves generated? (2)
- 7.4 A photon has $3,32 \times 10^{-19}$ J of energy.
 - 7.4.1 Define the term *photon*. (2)
 - 7.4.2 Write down the speed of a photon. (1)
 - 7.4.3 Calculate the frequency of this photon. (3)

Ultraviolet light, microwaves, gamma rays and visible light form part of the electromagnetic spectrum.

- 7.5 Which ONE of the electromagnetic radiations listed above has the following?
- 7.5.1 The lowest penetrating ability (1)
- 7.5.2 The shortest wavelength (1)
- 7.6 What is the relationship between wavelength and frequency of light? (2)
- [22]**

QUESTION 8 (Start on a new page.)

- 8.1 Define the term *capacitance*. (2)
- 8.2 Name ONE component of a capacitor. (1)
- 8.3 The minimum supply voltage of most household electrical appliances in South Africa is 230 V. A faulty capacitor in a pool pump is replaced with another that has the following specifications: 0,033 C; 300 μF .

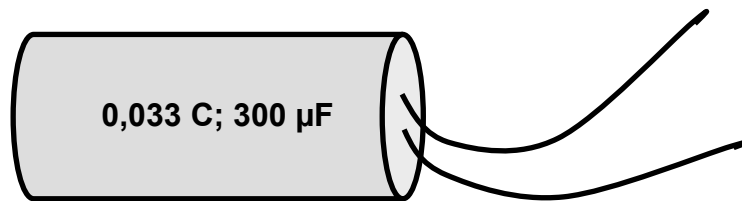

- 8.3.1 Determine, by using a calculation, whether the newly installed capacitor would be operational. (4)
- 8.3.2 Write down ONE way in which the capacitance of this capacitor can be decreased. (1)
- [8]**

QUESTION 9 (Start on a new page.)

In the circuit diagram below, the ammeter reads 3 A when switch **S** is closed. The resistance of the battery and ammeter can be ignored.

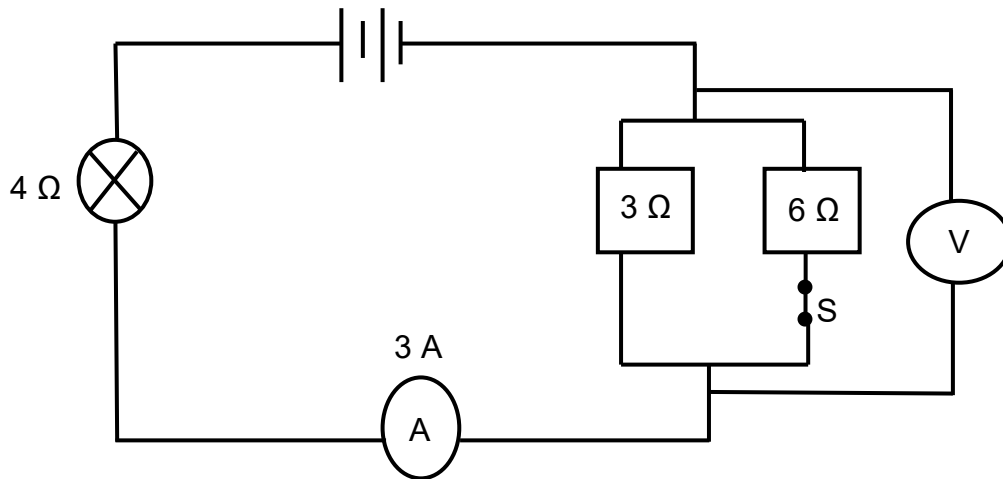

- 9.1 State ONE factor that affects the resistance of a conductor. (1)
 - 9.2 Calculate the:
 - 9.2.1 Power in the 4 Ω light bulb (3)
 - 9.2.2 Reading on the voltmeter (5)
- [9]**

QUESTION 10 (Start on a new page.)

- 10.1 State *Lenz's law* in words. (2)
- 10.2 Give TWO examples in technology where Lenz's law is used. (2)
- 10.3 In the diagram below, the current in a conductor comes out of the plane of a piece of paper at point **B** and enters at point **C**.

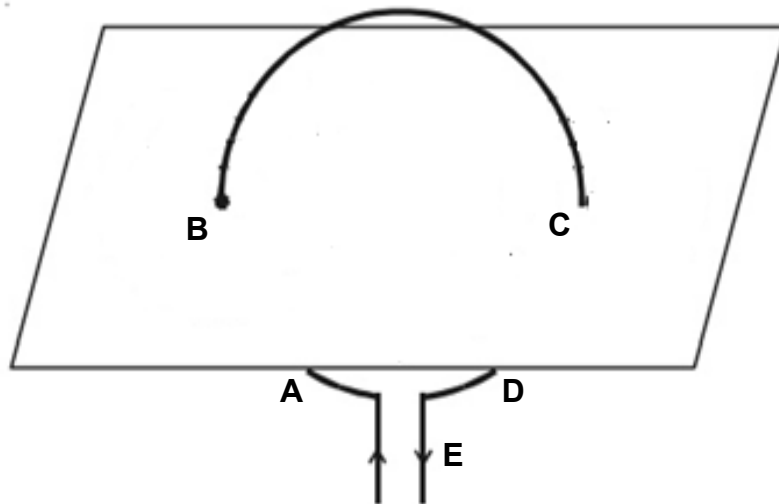

- 10.3.1 What is the direction of the induced magnetic field around the coil at point **E**? Write down only **CLOCKWISE** or **ANTICLOCKWISE**. (1)
- 10.3.2 Draw a diagram to illustrate the magnetic field pattern around the coil at points **B** and **C**. (3)
- 10.4 Study the diagram of a transformer below and answer the question that follows.

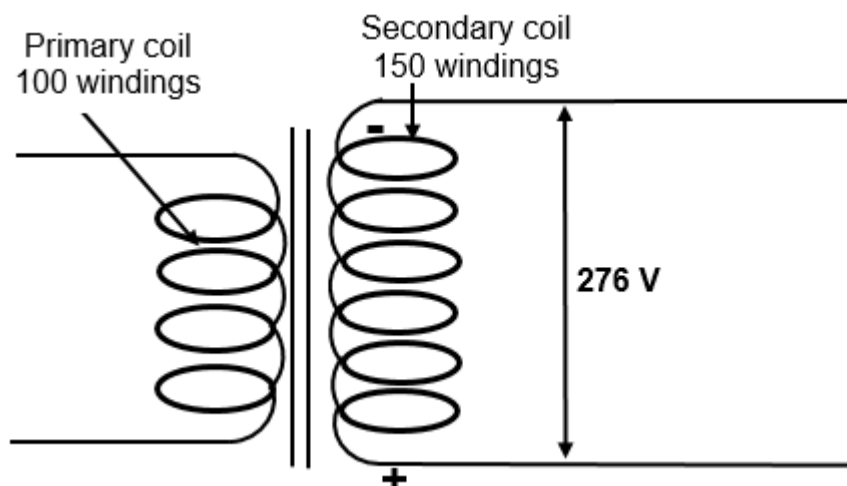

Calculate the voltage in the primary coil if the voltage in the secondary coil is 276 V.

(4)
[12]

TOTAL: 150

**DATA FOR TECHNICAL SCIENCES GRADE 12
PAPER 1**

**GEGEWENS VIR TEGNIESE WETENSKAPPE GRAAD 12
VRAESTEL 1**

TABLE 1: PHYSICAL CONSTANTS/TABEL 1: FISIESE KONSTANTES

NAME/NAAM	SYMBOL/SIMBOOL	VALUE/WAARDE
Acceleration due to gravity <i>Swaartekragversnelling</i>	g	9,8 m·s ⁻²
Speed of light in a vacuum <i>Spoed van lig in 'n vakuum</i>	c	3,0 x 10 ⁸ m·s ⁻¹
Planck's constant <i>Planck se konstante</i>	h	6,63 x 10 ⁻³⁴ J·s
Electron mass <i>Elektronmassa</i>	m _e	9,11 x 10 ⁻³¹ kg
Permittivity of free space <i>Permittiwiteit van vrye ruimte</i>	ε ₀	8,85 x 10 ⁻¹² F·m ⁻¹

TABLE 2: FORMULAE/TABEL 2: FORMULES

FORCE/KRAG

$F_{net} = ma$	$p = mv$
$f_s^{max} = \mu_s N$	$f_k = \mu_k N$
$F_{net} \Delta t = \Delta p$ $\Delta p = mv_f - mv_i$	$F_g = mg$
$v = \frac{\Delta x}{\Delta t}$	$a = \frac{\Delta v}{\Delta t}$

WORK, ENERGY AND POWER/ARBEID, ENERGIE EN DRYWING

$W = F \Delta x \cos \theta$	$U = mgh$ or/of $E_p = mgh$
$K = \frac{1}{2} mv^2$ or/of $E_k = \frac{1}{2} mv^2$	$M_E = E_k + E_p$
$P_{ave} = FV_{ave}$ / $P_{gemid} = FV_{gemid}$	$P = \frac{W}{\Delta t}$

ELASTICITY, VISCOSITY AND HYDRAULICS/ELASTISITEIT, VISKOSITEIT EN HIDROULIKA

$\sigma = \frac{F}{A}$	$\epsilon = \frac{\Delta l}{L}$
$\frac{\sigma}{\epsilon} = K$	$\frac{F_1}{A_1} = \frac{F_2}{A_2}$
$P = \frac{F}{A}$	$P = \rho gh$

ELECTROSTATICS/ELEKTROSTATIKA

$C = \frac{Q}{V}$	$C = \frac{\epsilon_0 A}{d}$
-------------------	------------------------------

CURRENT ELECTRICITY/STROOMELEKTRISITEIT

$R = \frac{V}{I}$	$R_s = R_1 + R_2 + \dots$ $\frac{1}{R_p} = \frac{1}{R_1} + \frac{1}{R_2} + \dots$
$W = VQ$ $W = VI\Delta t$ $W = I^2R \Delta t$ $W = \frac{V^2\Delta t}{R}$	$P = \frac{W}{\Delta t}$ $P = VI$ $P = I^2R$ $P = \frac{V^2}{R}$

ELECTROMAGNETISM/ELEKTROMAGNETISME

$\Phi = BA$	$\varepsilon = -N \frac{\Delta\Phi}{\Delta t}$
$\frac{V_s}{V_p} = \frac{N_s}{N_p}$	

WAVES, SOUND AND LIGHT/GOLWE, KLANK EN LIG

$v = f\lambda$	$T = \frac{1}{f}$
$E = hf$ <i>or/of</i> $E = h \frac{c}{\lambda}$	