



# basic education

Department:  
Basic Education  
**REPUBLIC OF SOUTH AFRICA**

**NATIONAL  
SENIOR CERTIFICATE**

**GRADE 12**

**ENGINEERING GRAPHICS AND DESIGN P2**  
**NOVEMBER 2025**

**MARKS: 100**

**TIME: 3 hours**

**This question paper consists of 6 pages.**

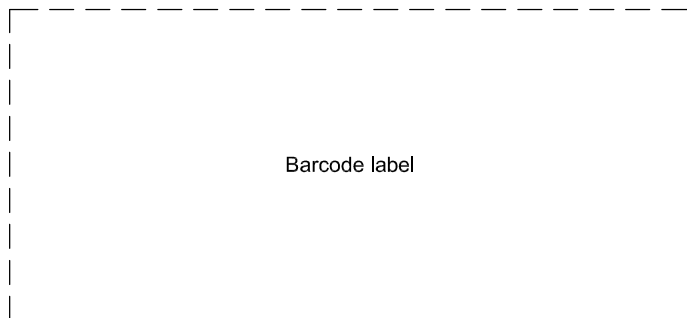

Barcode label

**DO NOT FOLD THE QUESTION PAPER IN HALF.**

## INSTRUCTIONS AND INFORMATION

1. This question paper consists of FOUR questions.
2. Answer ALL the questions.
3. ALL drawings are in third-angle orthographic projection, unless otherwise stated.
4. ALL drawings must be prepared using pencil and instruments, unless otherwise stated.
5. ALL answers must be drawn accurately and neatly.
6. ALL the questions must be answered on the QUESTION PAPER, as instructed.
7. ALL the pages, irrespective of whether the question was attempted or not, must be re-stapled in numerical sequence in the TOP LEFT-HAND CORNER ONLY.
8. Time management is essential in order to complete all the questions.
9. Print your examination number in the block provided on every page.
10. Any details or dimensions not given must be assumed in good proportion.

FOR OFFICIAL USE ONLY															
QUESTION	MARKS OBTAINED			$\frac{1}{2}$	SIGN	MODERATED			$\frac{1}{2}$	SIGN	RE-MARKING			$\frac{1}{2}$	SIGN
1															
2															
3															
4															
<b>TOTAL</b>															
	2	0	0			2	0	0			2	0	0		

FINAL CONVERTED MARK	CHECKED BY
100	

<b>COMPLETE THE FOLLOWING:</b>
CENTRE NUMBER
CENTRE NUMBER
EXAMINATION NUMBER
EXAMINATION NUMBER

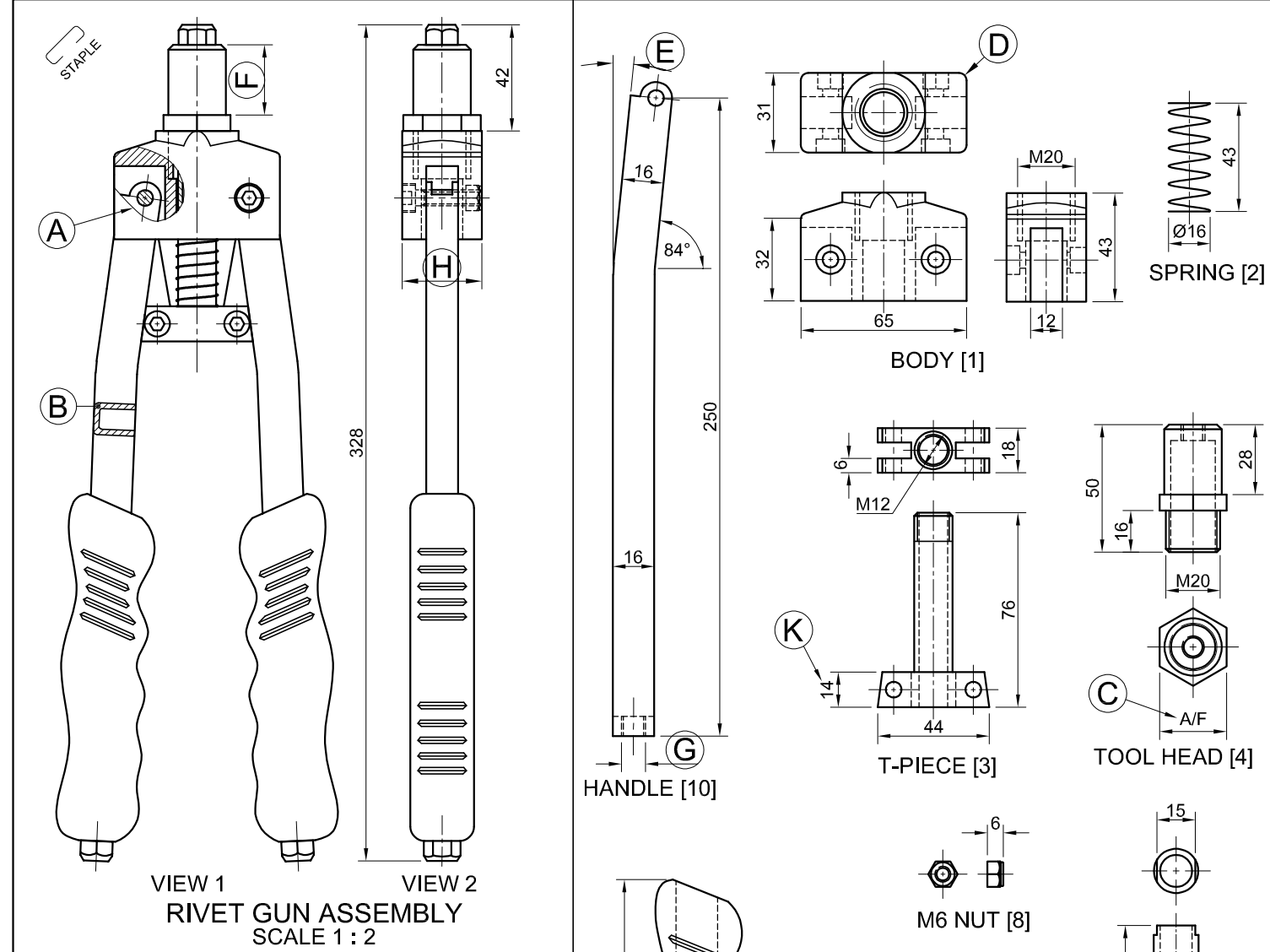

PARTS LIST			
NO.	PART	QUANTITY	MATERIAL
1	BODY	1	ALUMINIUM
2	SPRING	1	MILD STEEL
3	T-PIECE	1	MILD STEEL
4	TOOL HEAD	1	MILD STEEL
5	M6 BOLT	2	MILD STEEL
6	CONNECTOR	1	SPRING STEEL
7	PIN DIE	3	MILD STEEL
8	M6 NUT	2	MILD STEEL
9	LINK	4	MILD STEEL
10	HANDLE	2	MILD STEEL
11	GRIP	2	PLASTIC

FILE NAME: JJ-14213	QUANTITY: 75 RIVET GUNS	ALL UNSPECIFIED RADII ARE 3 mm.	TOLERANCE: +0,35 -0,25
DRAWING No. R0722	SCALE 1 : 2	ALL DIMENSIONS ARE IN MILLIMETRES.	
COMMISSIONED BY: CUSTOM CONTAINERS	DRAWING PROGRAMME: AUTOCAD 2024	DRAWN: TOBIAS	DATE: 03-07-2025
PRO-DRAUGHTSMEN CC 65 CHARLES ROAD, INDUSTRIA 6584	www.prodraw.co.za 099 050 6167	CHECKED: THOMAS	DATE: 23-07-2025
TITLE: RIVET GUN		APPROVED: KELLY	DATE: 13-08-2025

**QUESTION 1: ANALYTICAL (MECHANICAL)**

**Given:**

Two views of the assembled parts of a rivet gun assembly, detailed views of the parts of the assembly, a parts list, a title block and a table of questions. The drawings are not presented to the indicated scale.

**Instructions:**

Complete the table below by neatly answering the questions, which refer to the accompanying drawings, title block and mechanical content. [30]

QUESTIONS		ANSWERS	
1	What is the file name?		1
2	Who checked the drawing?		1
3	What is the name of the client?		1
4	What program has been used to prepare the drawing?		1
5	What is the website of the draughting company?		1
6	What projection system is indicated by the projection symbol?		1
7	How many handles must be manufactured to complete the order?		1
8	If VIEW 1 is the front view, what will VIEW 2 be called?		1
9	Name the type of section shown at A.		1
10	Name the type of section shown at B.		1
11	What does the abbreviation A/F at C stand for?		1
12	What is the radius of the rounding at D?		1
13	Determine the angle at E.		1
14	Determine the complete dimensions at: F: G: H: J:		4
15	With reference to the tolerance, determine the <b>maximum</b> and the <b>minimum</b> size of the dimension at K.	MAXIMUM: MINIMUM:	1 1
16	Calculate the height of a standard M30 nut.		1
17	With reference to the top machining symbol in the title block (QUESTION 17), what does the symbol indicate?		1
18	With reference to the bottom machining symbol in the title block (QUESTION 18), what do the letters 'b' and 'd' indicate?	b: d:	1 1
19	In the space below (ANSWER 19), complete, in neat freehand, FIGURE 19.2 as a sectional view of FIGURE 19.1 through the hole, with a SPOT FACE added to the hole.		4
20	In the space below (ANSWER 20), draw, to approximately the same size in neat freehand, the SANS 10111 conventional representation of the given SPLINED SHAFT.		3
<b>TOTAL</b>		<b>30</b>	

ANSWER 19

FIGURE 19.1

FIGURE 19.2

ANSWER 20

EXAMINATION NUMBER
EXAMINATION NUMBER

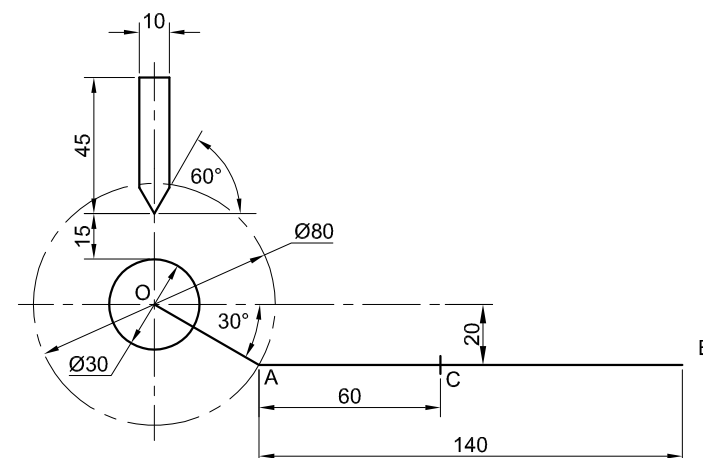

CAMSHAFT AND FOLLOWER DETAIL, AND MECHANISM DIAGRAM

**QUESTION 2: LOCI (CAM WITH A MECHANISM)**

**Given:**

- The detail of a camshaft and a wedge-shaped follower at the **minimum** distance from the camshaft centre
- Fixed to the given camshaft is a mechanism, consisting of crank OA, connecting rod AB and swivel guide C, shown as a schematic diagram
- The position of centre point O on the drawing sheet

**Specifications of the cam:**

- The wedge-shaped follower reciprocates along the vertical centre line of the camshaft.
- Rotation = clockwise.

**Motion of the cam:**

The cam imparts the following motion to the wedge-shaped follower:

- It rises 25 mm over the first 75° with uniform motion.
- It rises a further 26 mm over the next 90° with simple harmonic motion.
- There is a dwell period for the next 15°.
- It returns to its original position with uniform motion over the remainder of the rotation.

**Specifications of the mechanism:**

- Connecting rod AB is pin-joined to crank OA at A.
- The position of swivel guide C is fixed.

**Motion of the mechanism:**

As crank OA rotates with the camshaft, connecting rod AB slides through swivel guide C.

**Instructions:**

- Using centre point O on the drawing sheet, draw, to scale 1 : 1, the given **camshaft** and **wedge-shaped follower detail** at the **minimum position**, together with the **schematic diagram** of the **mechanism**.
- Draw, to a rotational scale of 30° = 8 mm and a displacement scale of 1 : 1, the displacement graph for the required motion of the cam.
- Project and draw the complete cam profile from the displacement graph.
- Show the direction of rotation of the cam profile with an arrow.
- Indicate the rotational scale of the displacement graph.
- Trace the locus generated by point B of the **mechanism** for ONE complete rotation of the camshaft.
- Show ALL construction and projection. [41]

ASSESSMENT CRITERIA: CAM				ASSESSMENT CRITERIA: MECHANISM			
1	GIVEN + MINIMUM DISTANCE + CL	4 1/2		1	GIVEN	3 1/2	
2	GRAPH CONSTRUCTION	3 1/2		2	CONSTRUCTION	3	
3	PLOTTING GRAPH + GRAPH CURVES	6		3	POINTS + CURVE	7	
4	CAM CONSTRUCTION	4		PENALTIES (-)			
5	PLOTTING + CAM PROFILE	9 1/2		<b>SUBTOTAL</b>			
				<b>TOTAL</b>		<b>41</b>	
<b>SUBTOTAL</b>				EXAMINATION NUMBER			
				EXAMINATION NUMBER			
				3			



**QUESTION 3: ISOMETRIC DRAWING**

**Given:**

- The front view, top view and right view of a casting
- The position of point P on the drawing sheet

**Instructions:**

Using scale 1 : 1, convert the orthographic views of the casting into an isometric drawing.

- Use point P as the starting point of the drawing.
- Show ALL construction.
- NO hidden detail is required.

[39]

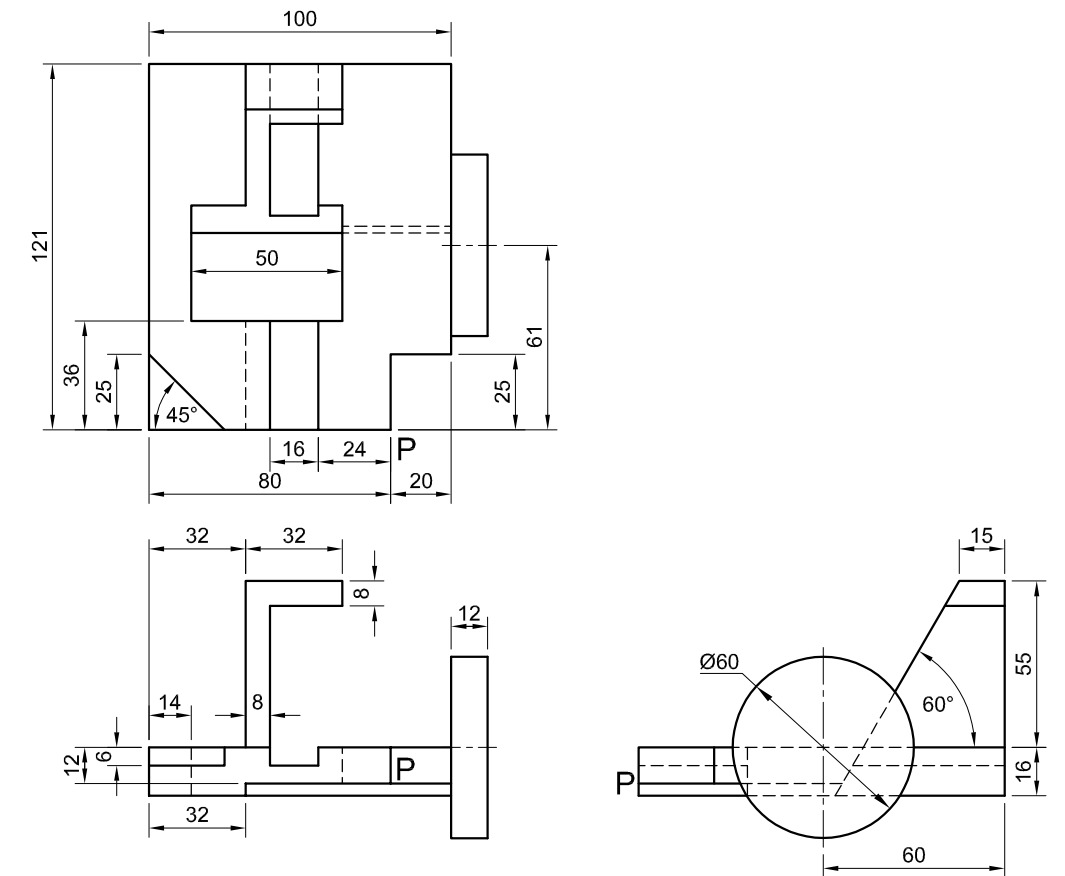

↓  
P

ASSESSMENT CRITERIA			
1	PLACING + AUX. VIEW	2	
2	FRONT PORTION	14 1/2	
3	BACK PORTION	14 1/2	
4	CIRCLES + CONSTR. + CL	8	
PENALTIES (-)			
<b>TOTAL</b>		<b>39</b>	
EXAMINATION NUMBER			
EXAMINATION NUMBER			
			4





FOR OFFICIAL USE ONLY	
INCORRECT ORTHOGRAPHIC PROJECTION	
INCORRECT OVERALL SCALE	
INCORRECT HATCHING	
PARTS NOT ASSEMBLED	
TOTAL PENALTIES (-)	

ASSESSMENT CRITERIA					
RIGHT VIEW					
		POSSIBLE	OBTAINED	SIGN	MODERATED
1	HOUSING + SYMMETRY	6			
2	COVER + SCREWS	4			
3	FLANGE COUPLING	2			
4	M16 NUT + SHAFT	4			
<b>SUBTOTAL</b>		<b>16</b>			
SECTIONAL FRONT VIEW					
1	HOUSING	10 $\frac{1}{2}$			
2	COVER	4 $\frac{1}{2}$			
3	M10 SCREW	7			
4	SPUR GEAR	9			
5	BALL BEARING	2 $\frac{1}{2}$			
6	SHAFT + KEY + BUSH	15 $\frac{1}{2}$			
7	FLANGE COUPLING	9			
8	M16 NUT	4			
<b>SUBTOTAL</b>		<b>62</b>			
GENERAL					
1	CENTRE LINES	3			
2	ASSEMBLY	9			
<b>SUBTOTAL</b>		<b>12</b>			
<b>TOTAL</b>		<b>90</b>			
PENALTIES (-)					
<b>GRAND TOTAL</b>					
EXAMINATION NUMBER					
EXAMINATION NUMBER					