

Confidential



basic education

Department:
Basic Education
REPUBLIC OF SOUTH AFRICA

**NATIONAL
SENIOR CERTIFICATE**

GRADE 12

ELECTRICAL TECHNOLOGY: POWER SYSTEMS

NOVEMBER 2025

MARKS: 200

TIME: 3 hours

This question paper consists of 20 pages and a 2-page formula sheet.

INSTRUCTIONS AND INFORMATION

1. This question paper consists of SEVEN questions.
2. Answer ALL the questions.
3. Sketches and diagrams must be large, neat and FULLY LABELLED.
4. Show ALL calculations and round off answers correctly to TWO decimal places.
5. Number the answers correctly according to the numbering system used in this question paper.
6. You may use a non-programmable calculator.
7. Calculations must include:
 - 7.1 Formulae and manipulations where needed
 - 7.2 Correct replacement of values
 - 7.3 Correct answer and relevant units where applicable
8. A formula sheet is attached at the end of this question paper.
9. Write neatly and legibly.

QUESTION 1: MULTIPLE-CHOICE QUESTIONS

Various options are provided as possible answers to the following questions. Choose the answer and write only the letter (A–D) next to the question numbers (1.1 to 1.15) in the ANSWER BOOK, e.g. 1.16 D.

- 1.1 A/An ... provides work for another person and remunerates that person.
- A employee
 - B employer
 - C supervisor
 - D health and safety representative
- (1)
- 1.2 The phase difference between the voltage across the capacitor and the voltage across the resistor in an RC series circuit is ...
- A 0°
 - B 90°
 - C 120°
 - D 180°
- (1)
- 1.3 In an RLC series circuit, the total current lags the supply voltage. This is an indication that the frequency is ... resonance.
- A below
 - B equal to
 - C above
- (1)
- 1.4 The total impedance in an RLC parallel circuit with a variable frequency supply is equal to the ... at resonance.
- A inductive reactance
 - B capacitive reactance
 - C resistance
- (1)
- 1.5 The ... of the same amount of electrical power is more economical in a three-phase system than in a single-phase system.
- A generation
 - B transmission
 - C distribution
 - D All the above-mentioned
- (1)
- 1.6 ... are used to improve the power factor of induction motors and are mounted on the same shaft as the rotor.
- A Static capacitors
 - B Phase advancers
 - C Inductors
 - D Variable resistors
- (1)

- 1.7 A ... is used by electric service providers to measure the electric energy delivered to their customers for billing purposes.
- A wattmeter
 - B kilowatt-hour meter
 - C ammeter
 - D voltmeter
- (1)
- 1.8 ... configuration is seldom used in three-phase transformers due to the presence of harmonics in the secondary windings.
- A Star-star
 - B Star-delta
 - C Delta-star
 - D Delta-delta
- (1)
- 1.9 Eddy currents form part of ...
- A copper losses.
 - B iron losses.
 - C stray losses.
 - D dielectric losses.
- (1)
- 1.10 The primary function of the stator in a three-phase induction motor is to ...
- A rotate and produce mechanical power.
 - B provide an electrical connection between the rotor and stator.
 - C create a rotating magnetic field when connected to a three-phase supply.
 - D ensure conductivity between the coils and the earth.
- (1)
- 1.11 By reversing the connections of any two of the three-phase supply lines in a three-phase induction motor, the direction of rotation will change because the ...
- A polarity on the contactor coil changed.
 - B phase sequence of the supply voltage to the stator coils changed.
 - C frequency of the power supply is inverted.
 - D motor windings are short-circuited.
- (1)
- 1.12 Once the start button is pressed in a three-phase automatic star-delta motor starter, ... is/are energised.
- A only the main contactor
 - B the star and delta contactors
 - C the main contactor and delta contactor
 - D the main contactor and star contactor
- (1)

- 1.13 A ... is an example of an output device on a PLC.
- A switch
 - B sensor
 - C relay
 - D strain gauge
- (1)
- 1.14 A semiconductor device that uses light to transfer an electrical signal between circuits or elements of a circuit is called a/an ...
- A diode.
 - B transistor.
 - C opto-coupler.
 - D Zener diode.
- (1)
- 1.15 The IGBT in a VSD is simulated by using pairs of switches. Which ONE of the following simulation statements is CORRECT?
- A One pair of switches controls the negative output voltage.
 - B One pair of switches controls the positive output voltage.
 - C One switch in a pair controls both the positive and negative output voltage.
 - D None of the above-mentioned
- (1)
[15]

QUESTION 2: OCCUPATIONAL HEALTH AND SAFETY

- 2.1 Explain *machinery* with reference to the Occupational Health and Safety Act, 1993 (Act 85 of 1993). (2)
- 2.2 State TWO precautionary measures to protect yourself when assisting someone that has been electrocuted. (2)
- 2.3 Give TWO examples of dangerous practices in the electrical workshop. (2)
- 2.4 Differentiate between a *critical incident* and an *accident*. (2)
- 2.5 In the electrical workshop, you saw one of your classmates removing a safety guard on a machine. According to the Occupational Health and Safety Act, 1993 (Act 85 of 1993), this is an unsafe act. Motivate why it is an unsafe act. (2)
[10]

QUESTION 3: RLC CIRCUITS

3.1 With reference to RLC circuits, state the correct terminology that describes the following:

3.1.1 The frequency at which X_L is equal to X_C (1)

3.1.2 The ratio of the energy stored to the energy converted by an inductor or capacitor (1)

3.2 FIGURE 3.2 below shows an RLC series circuit connected to an AC supply. Answer the questions that follow.

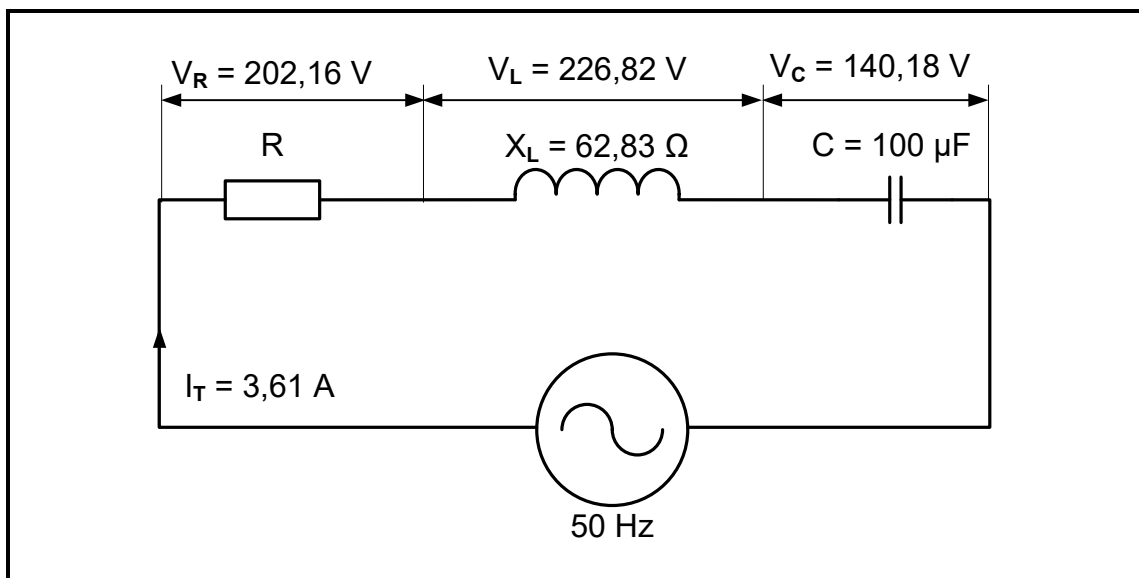

FIGURE 3.2: RLC SERIES CIRCUIT

Given:

I_T	= 3,61 A
X_L	= 62,83 Ω
C	= 100 μF
V_R	= 202,16 V
V_L	= 226,82 V
V_C	= 140,18 V
f	= 50 Hz

Calculate the following:

3.2.1 Supply voltage (3)

3.2.2 Impedance (3)

3.2.3 Phase angle (3)

3.2.4 Capacitance value that will cause resonance (3)

3.3 Redraw and complete the voltage phasor diagram of QUESTION 3.2 in FIGURE 3.3 below in the ANSWER BOOK.

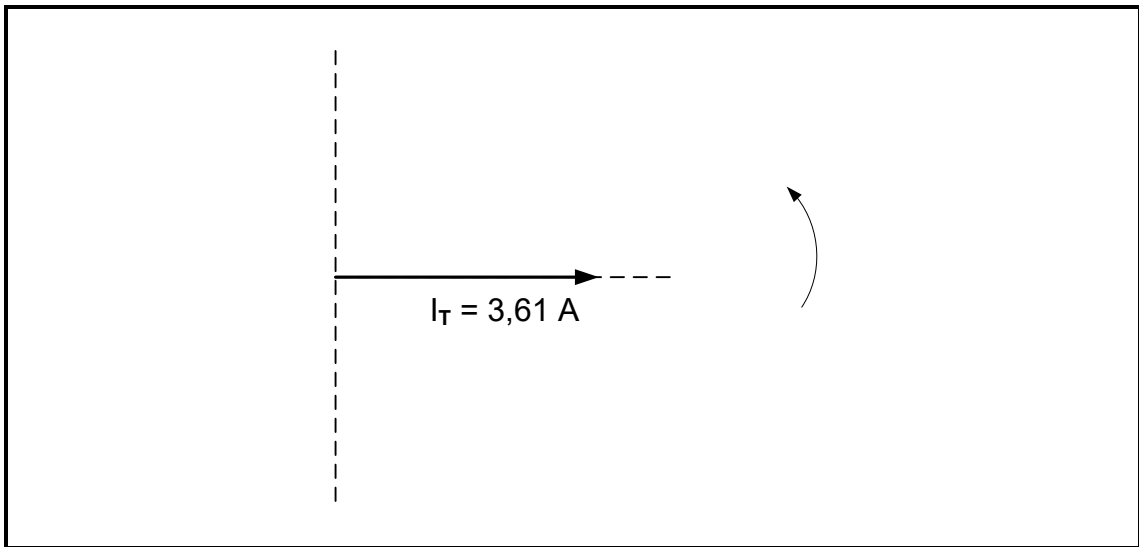

FIGURE 3.3: INCOMPLETE VOLTAGE PHASOR DIAGRAM

(4)

3.4 FIGURE 3.4 below shows an RLC parallel circuit with its corresponding phasor diagram. Answer the questions that follow.

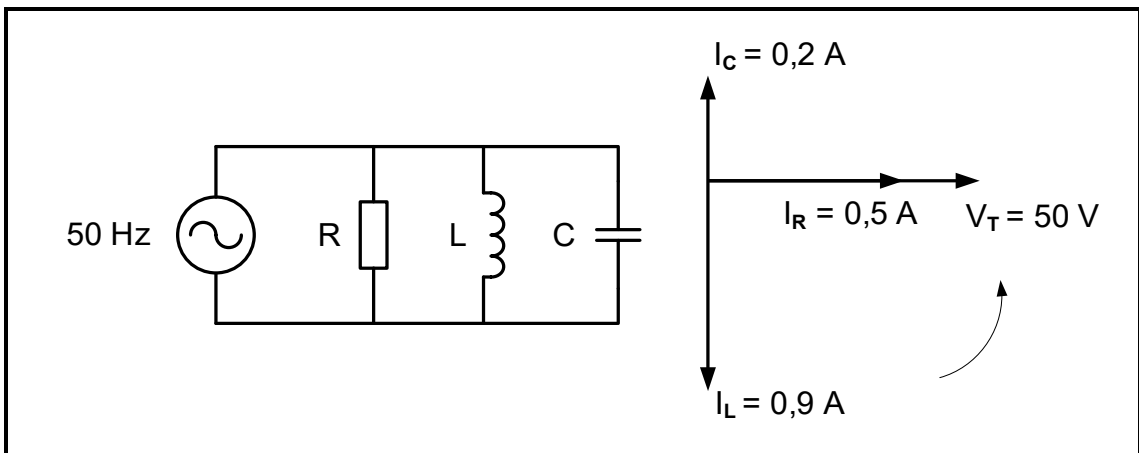

FIGURE 3.4: RLC PARALLEL CIRCUIT AND PHASOR DIAGRAM

Given:

- $V_T = 50 \text{ V}$
- $I_R = 0,5 \text{ A}$
- $I_L = 0,9 \text{ A}$
- $I_C = 0,2 \text{ A}$
- $f = 50 \text{ Hz}$

Calculate the following:

3.4.1 Total current (3)

3.4.2 Capacitive reactance (3)

- 3.5 State whether the circuit in FIGURE 3.4 on the previous page is more capacitive or more inductive. Give a reason for the answer. (2)
- 3.6 Refer to FIGURE 3.4 on the previous page and explain how an increase in the supply frequency will cause the circuit to resonate. (3)
- 3.7 FIGURE 3.7 below shows the frequency response curve of an RLC circuit, NOT to scale. Answer the questions that follow.

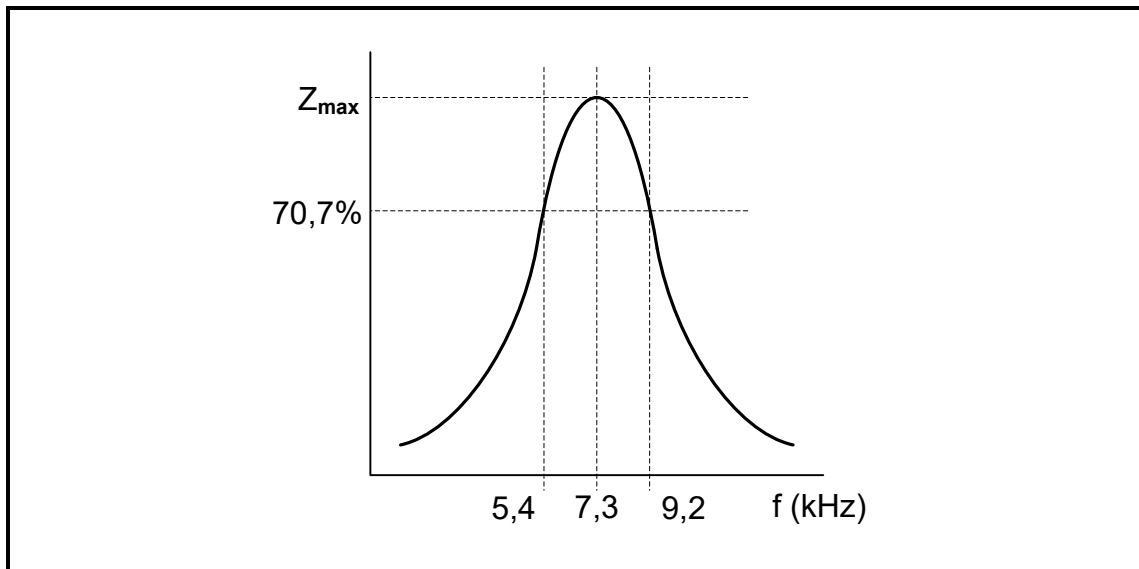

FIGURE 3.7: Q-FACTOR CHARACTERISTIC CURVE

- 3.7.1 State whether FIGURE 3.7 above represents the response curve for a series or parallel RLC circuit and motivate the answer. (2)
- 3.7.2 Calculate the Q-factor of the circuit. (4)

[35]

QUESTION 4: THREE-PHASE AC GENERATION

- 4.1 State TWO disadvantages of three-phase systems. (2)
- 4.2 Describe what is meant by a *power factor of less than 1* in a three-phase system. (2)
- 4.3 Refer to FIGURE 4.3 below which shows the coil configuration of a balanced three-phase system connected to a 400 V three-phase supply. Answer the questions that follow.

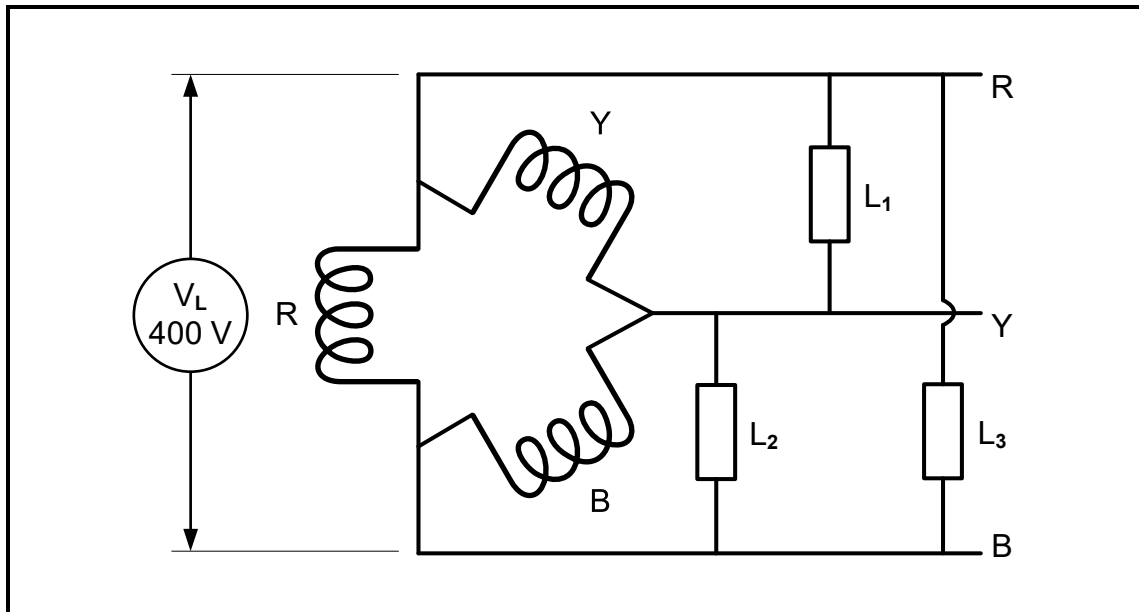
**FIGURE 4.3: BALANCED THREE-PHASE LOAD**

- 4.3.1 Identify the configuration of the coils in FIGURE 4.3 above. (1)
- 4.3.2 Determine the voltage across L_2 in FIGURE 4.3 above. (1)
- 4.3.3 Draw the phasor diagram of the system in FIGURE 4.3 above. (4)
- 4.4 A 16 kVA star-connected generator is used to power a three-phase load. The phase voltage is 220 V and the phase angle is $29,54^\circ$.
- Given:
- $S = 16 \text{ kVA}$
 $V_{PH} = 220 \text{ V}$
 $\theta = 29,54^\circ$
- Calculate the following:
- 4.4.1 Line voltage (3)
- 4.4.2 Line current at full load (3)
- 4.4.3 Active power (3)
- 4.4.4 Reactive power (3)
- 4.5 The input power to a three-phase system is 3,45 kW. The system is able to deliver 3,2 kW of effective power on the output. Calculate the efficiency of the system. (3)

4.6 FIGURE 4.6 below shows the connection of an analogue wattmeter to one of the phases of a three-phase load. Answer the questions that follow.

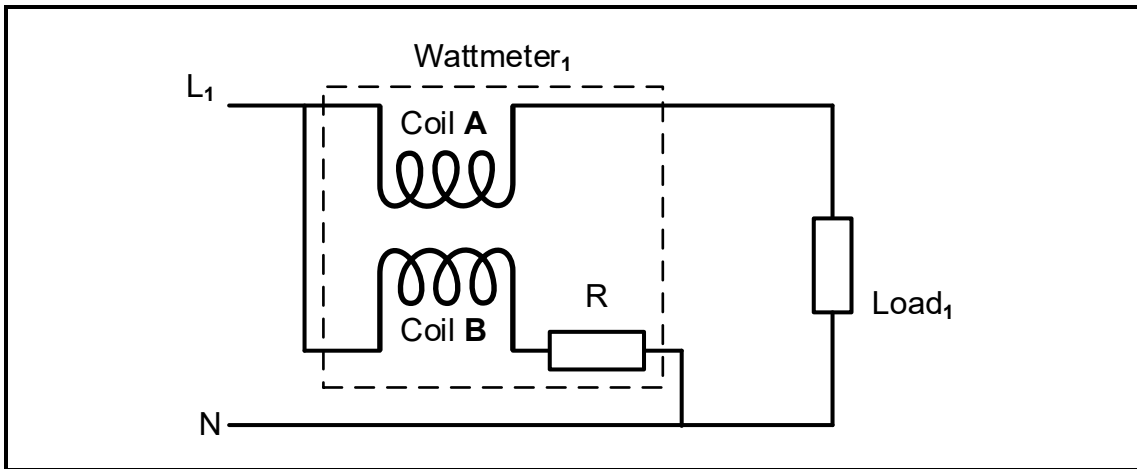

FIGURE 4.6: WATTMETER CONNECTION

- 4.6.1 Identify coil **A** in FIGURE 4.6 above. (1)
- 4.6.2 Explain TWO advantages of digital wattmeters compared to analogue wattmeters. (2)
- 4.6.3 Describe the function of coil **B** in FIGURE 4.6 above. (2)

4.7 FIGURE 4.7 below shows how a power factor meter is connected to a three-phase balanced load network. Answer the questions that follow.

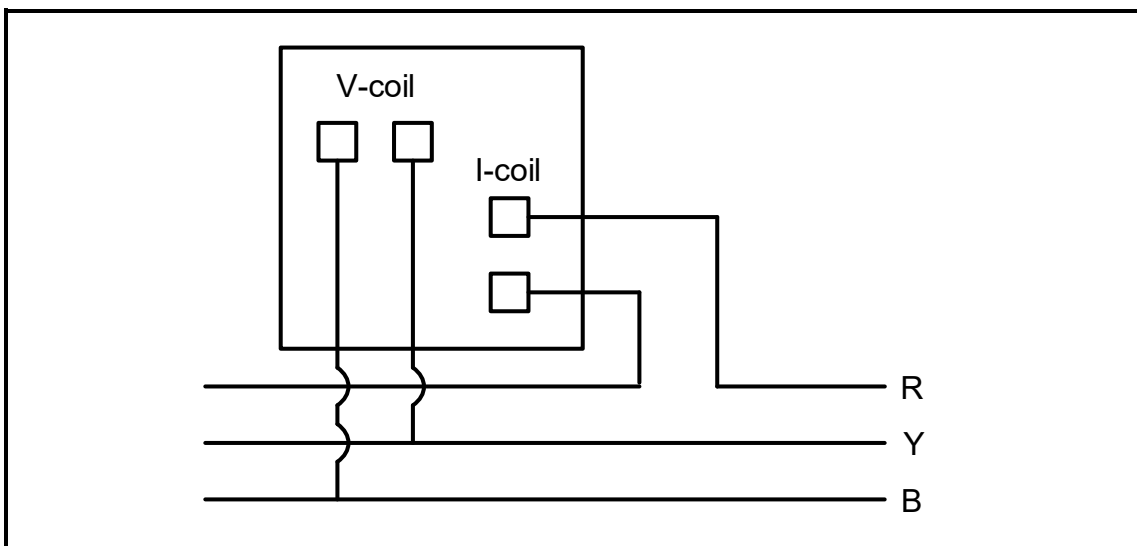

FIGURE 4.7: POWER FACTOR METER CONNECTION

- 4.7.1 Name TWO disadvantages of having a low power factor. (2)
- 4.7.2 Explain the purpose of a power factor meter. (1)
- 4.7.3 Describe how current is affected in a system when the load has a low power factor compared to the same load with a higher power factor. Motivate your answer. (2)

[35]

QUESTION 5: THREE-PHASE TRANSFORMERS

- 5.1 Explain *mutual inductance* as the principle of operation of transformers. (2)
- 5.2 Refer to FIGURE 5.2 below and answer the questions that follow.

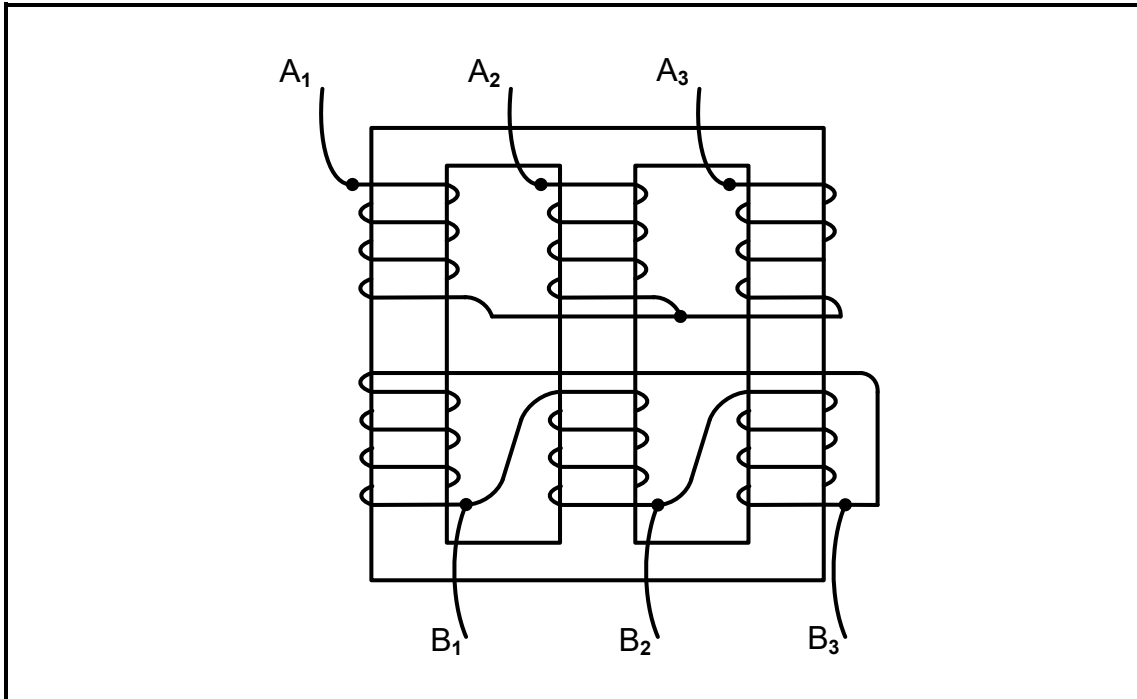
**FIGURE 5.2: THREE-PHASE TRANSFORMER**

- 5.2.1 State the configuration in which coils A_1 – A_3 and B_1 – B_3 are connected. (2)
- 5.2.2 Explain why an iron core is used in the construction of a transformer. (3)
- 5.2.3 State if FIGURE 5.2 above represents a core type or a shell type transformer. Motivate your answer. (2)
- 5.2.4 Explain how dry type transformers dissipate heat when operating. (1)

5.3 Refer to FIGURE 5.3 below and answer the questions that follow.

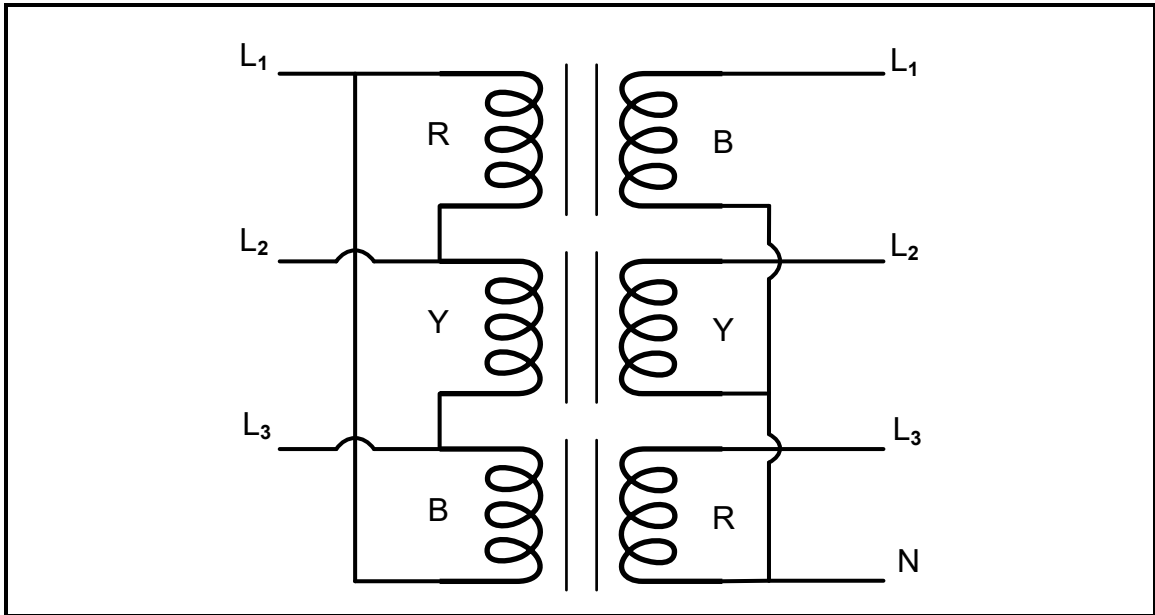

FIGURE 5.3: THREE SINGLE-PHASE TRANSFORMERS CONNECTED AS A THREE-PHASE TRANSFORMER

- 5.3.1 Name ONE characteristic that must be identical in all three transformers for it to be used as a three-phase unit. (1)
- 5.3.2 Name ONE application of the configuration used in FIGURE 5.3 above. (1)
- 5.3.3 Explain the advantage of three single-phase transformers connected as a single three-phase unit when one set of coils is damaged. (2)

5.4 A three-phase transformer with a primary connected in delta and the secondary connected in star has a primary line voltage of 6 600 V. The secondary line voltage is 380 V. The transformer has an efficiency of 100%.

Given:

$$V_{L1} = 6\ 600\ \text{V}$$

$$V_{L2} = 380\ \text{V}$$

$$\eta = 100\%$$

- 5.4.1 Determine the primary phase voltage. (2)

Calculate the following:

- 5.4.2 Secondary phase voltage (3)
- 5.4.3 Turns ratio (3)
- 5.4.4 The primary phase current if the secondary line current is 900 A (3)

5.5 A three-phase transformer powers a load of 4 500 W. The efficiency of the transformer is 96%. Calculate the total losses of the transformer in watts. (3)

5.6 Describe the function of the conservator during the operation of transformers. (2)

[30]

QUESTION 6: THREE-PHASE MOTORS AND STARTERS

- 6.1 Name TWO electrical tests to be conducted on a three-phase motor. (2)
- 6.2 Explain *reactive power* with reference to a three-phase induction motor. (2)
- 6.3 Refer to FIGURE 6.3 below and answer the questions that follow.

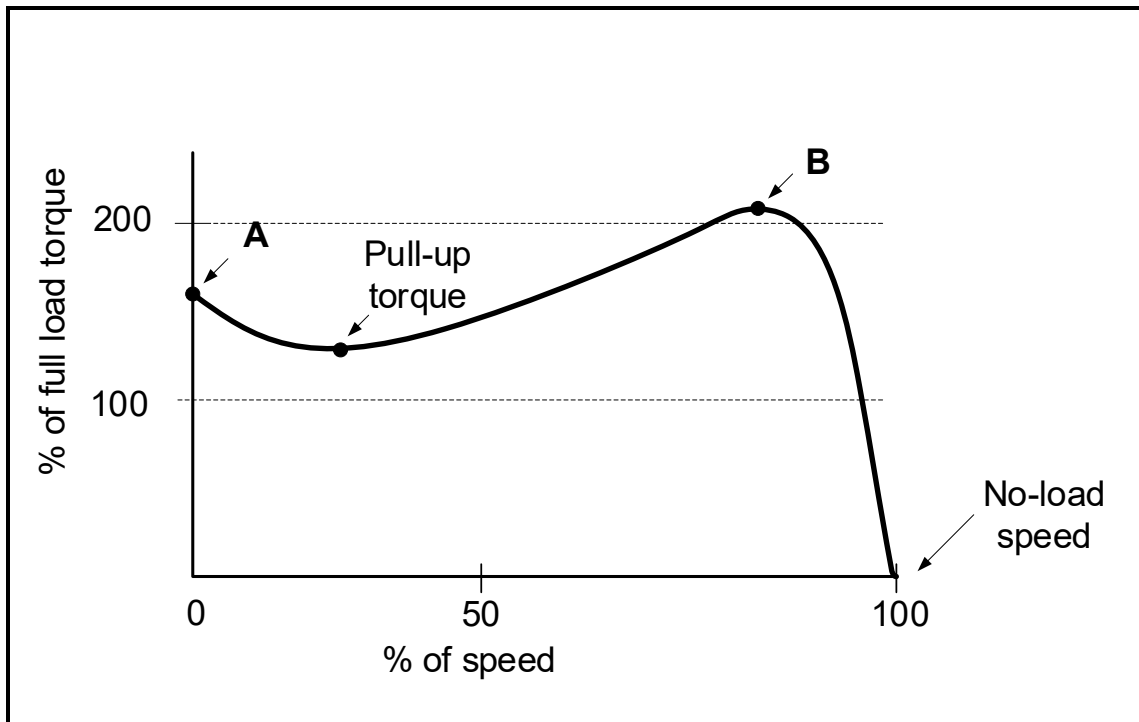

FIGURE 6.3: SPEED VERSUS TORQUE CHARACTERISTIC CURVE

- 6.3.1 Label **A** and **B** on the characteristic curve in FIGURE 6.3 above. (2)
 - 6.3.2 State whether the slip is minimum or maximum at no-load speed. (1)
- 6.4 The rotor of a three-phase induction motor with 2 pole pairs per phase rotates at 1 250 r/min when connected to a 400 V/50 Hz supply.

Given:

- $V_L = 400 \text{ V}$
- $f = 50 \text{ Hz}$
- $n_r = 1\,250 \text{ r/min}$
- $p = 2$

Calculate the following:

- 6.4.1 Synchronous speed of the motor (3)
- 6.4.2 Percentage slip (3)

6.5 A three-phase induction motor is able to deliver 4 kW of output power at full load. The motor has a power factor of 0,85 and draws a line current of 6,8 A from the supply at full load.

Given:

$P_{out} = 4 \text{ kW}$
 $I_L = 6,8 \text{ A}$
 $pf = 0,85$

Assume that there are no losses and calculate the following:

- 6.5.1 Phase angle (3)
- 6.5.2 Supply voltage (3)
- 6.5.3 Apparent power (3)
- 6.5.4 Reactive power (3)

6.6 The circuit in FIGURE 6.6 below is used to control a three-phase motor. The motor must be able to rotate in a forward direction and in a reverse direction, but NOT at the same time. Answer the questions that follow.

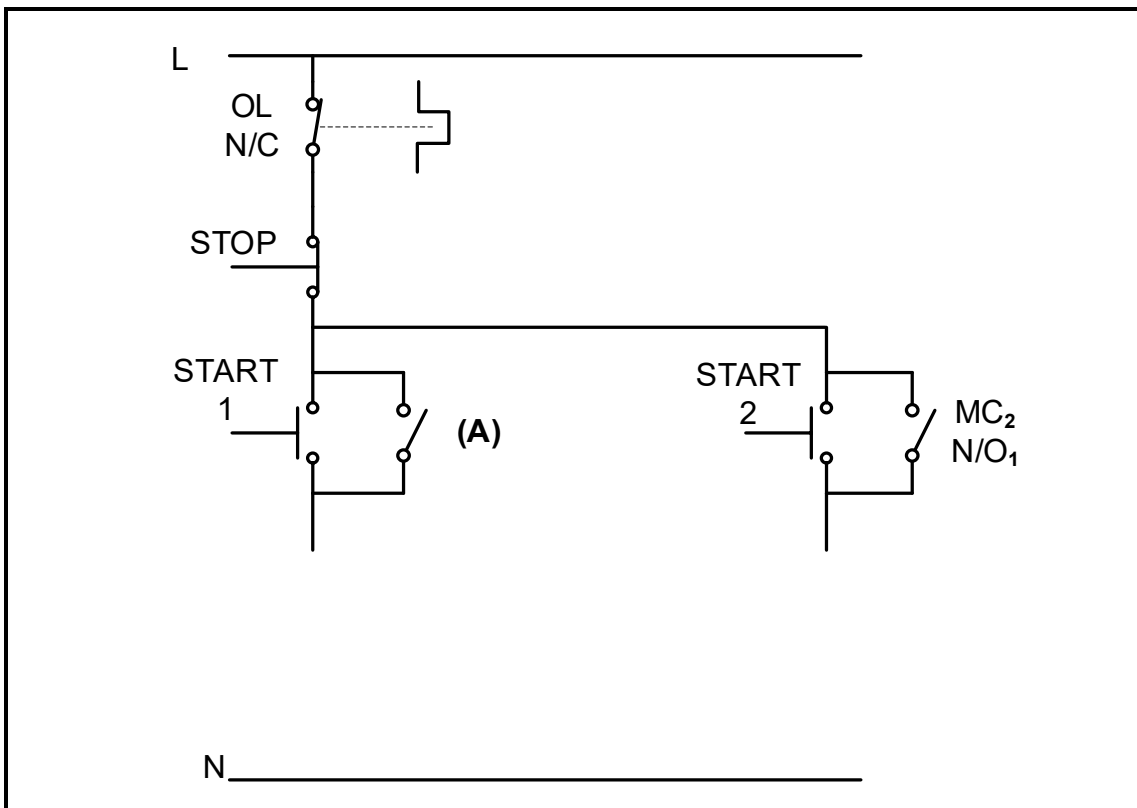

FIGURE 6.6: FORWARD-REVERSE CONTROL CIRCUIT

- 6.6.1 Label **A** in FIGURE 6.6 above. (1)
- 6.6.2 Explain the condition that will open OL N/C during the operation of the circuit. (1)
- 6.6.3 Explain the need for having TWO main contactors in the circuit. (2)

- 6.6.4 Name the connection needed to prevent the simultaneous forward and reverse operation of the motor. (1)
- 6.6.5 Redraw and complete in your ANSWER BOOK the control circuit for FIGURE 6.6, on the previous page, that satisfies the requirements of QUESTION 6.6. (4)
- 6.6.6 State how a faulty stop button, that remains permanently open, would affect the operation of the circuit. (1)
- [35]**

QUESTION 7: PROGRAMMABLE LOGIC CONTROLLERS (PLCs)

7.1 Refer to FIGURE 7.1 below of the programmed scan cycle of a PLC and answer the questions that follow.

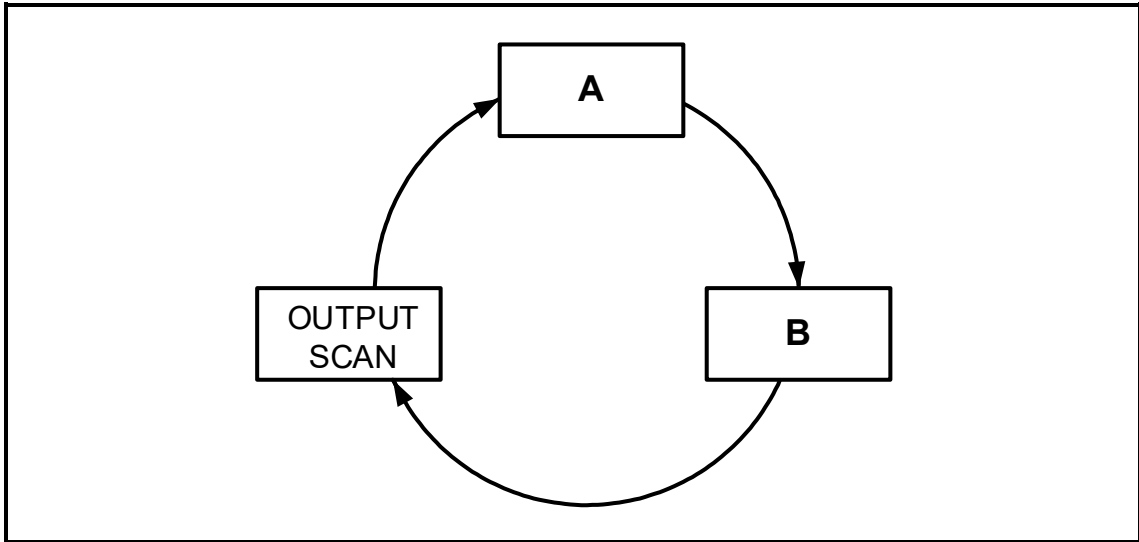

FIGURE 7.1: PLC SCAN CYCLE

7.1.1 Label **A** and **B**. (2)

7.1.2 Explain the *output scan*. (2)

7.2 State TWO advantages of a PLC system over a hardwired relay system, with reference to cost. (2)

7.3 Explain why the PLC wiring and connections must be checked before switching on. (2)

7.4 Explain why a PLC system is safer than a hardwired system when a fault condition occurs. (2)

7.5 State the purpose of the following PLC program functions:

7.5.1 Markers/Flags (2)

7.5.2 Contactor (2)

7.6 Refer to FIGURE 7.6 below and answer the questions that follow.

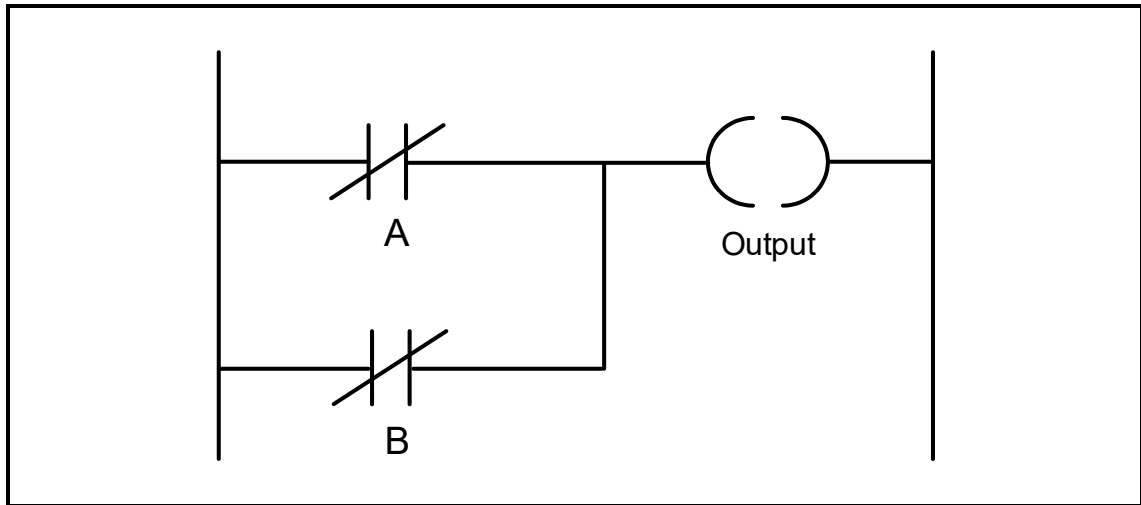

FIGURE 7.6: PLC LOGIC FUNCTION

7.6.1 Draw the equivalent logic symbol of FIGURE 7.6 above. (3)

7.6.2 Complete the truth table in TABLE 7.6.2 below by writing down only the state of the output in the ANSWER BOOK.

A	B	OUTPUT
0	1	(X)
1	1	(Y)

TABLE 7.6.2

(2)

7.7 FIGURE 7.7(A) below shows the relay diagram of a manual sequence starter. Redraw and complete the PLC ladder logic diagram in FIGURE 7.7(B), that will execute the same function in a PLC system, in the ANSWER BOOK.

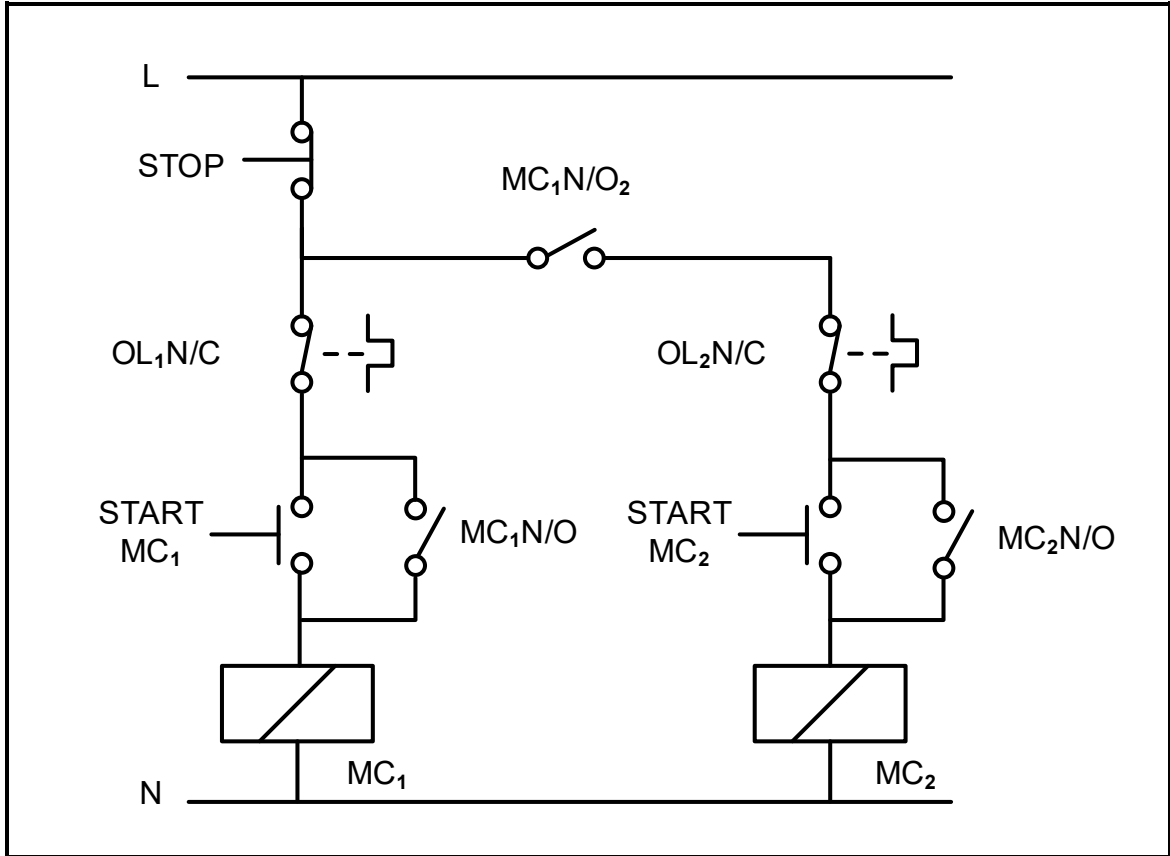

FIGURE 7.7(A): CONTROL CIRCUIT OF A MANUAL SEQUENCE STARTER



FIGURE 7.7(B)

(9)

7.8 FIGURE 7.8 below shows the characteristic curves of the VSD when it is used to control the speed of a three-phase induction motor. Study the characteristic curves and answer the questions that follow.

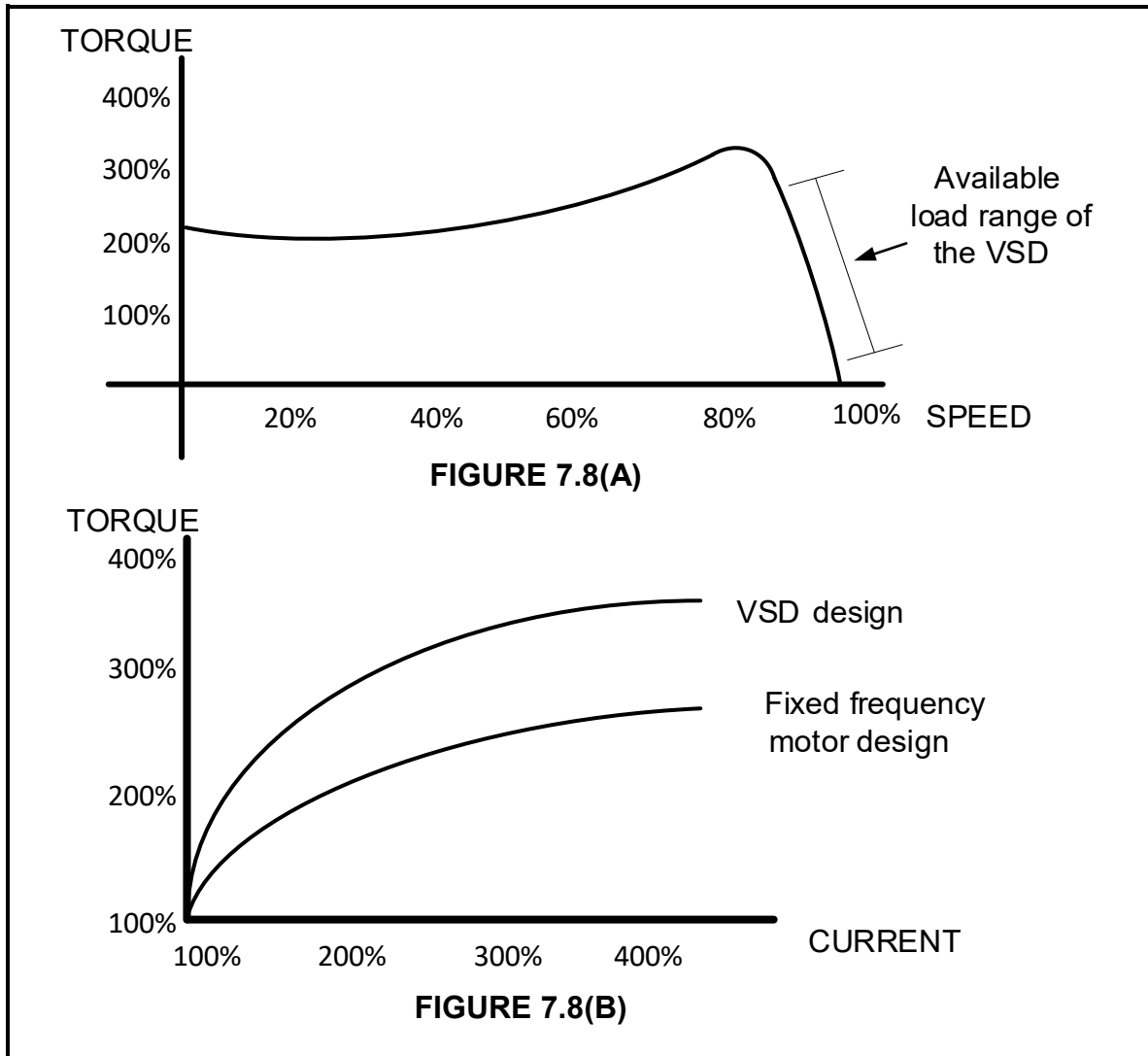

FIGURE 7.8: VSD TORQUE VERSUS SPEED AND TORQUE VERSUS CURRENT GRAPHS

- 7.8.1 Compare the characteristics in FIGURE 7.8(B) above and state the improvement a VSD motor design has compared to a fixed frequency motor design. (2)
- 7.8.2 Refer to FIGURES 7.8(A) and 7.8(B) above and state TWO advantages for industries and manufacturers when using a VSD to control the speed of a motor. (2)

- 7.9 Name the component used to dissipate the excessive energy during the process of regenerative braking. (1)
- 7.10 Name THREE applications of a VSD. (3)
- 7.11 Explain how the three-phase AC supply is changed to DC, with reference to the first stage in a VSD. (2)
- 7.12 Explain how longer ON times affect the output frequency of a VSD during the process of pulse width modulation (PWM). (2)
- [40]**
- TOTAL: 200**

FORMULA SHEET

RLC CIRCUITS	THREE-PHASE AC GENERATION
<p>$P = V I \cos \theta$</p> <p>$X_L = 2\pi fL$</p> <p>$X_C = \frac{1}{2\pi fC}$</p> <p>$f_r = \frac{1}{2\pi\sqrt{LC}}$ OR $f_r = \frac{f_1 + f_2}{2}$</p> <p>$BW = \frac{f_r}{Q}$ OR $BW = f_2 - f_1$</p> <p>SERIES</p> <p>$V_R = IR$</p> <p>$V_L = IX_L$</p> <p>$V_C = IX_C$</p> <p>$I_T = \frac{V_T}{Z}$ OR $I_T = I_R = I_C = I_L$</p> <p>$Z = \sqrt{R^2 + (X_L - X_C)^2}$</p> <p>$V_T = \sqrt{V_R^2 + (V_L - V_C)^2}$ OR $V_T = IZ$</p> <p>$\cos \theta = \frac{R}{Z}$ OR $\cos \theta = \frac{V_R}{V_T}$</p> <p>$Q = \frac{X_L}{R} = \frac{X_C}{R} = \frac{V_L}{V_T} = \frac{V_C}{V_T} = \frac{1}{R} \sqrt{\frac{L}{C}}$</p> <p>PARALLEL</p> <p>$V_T = V_R = V_C = V_L$</p> <p>$I_R = \frac{V_T}{R}$</p> <p>$I_C = \frac{V_T}{X_C}$</p> <p>$I_L = \frac{V_T}{X_L}$</p> <p>$I_T = \sqrt{I_R^2 + (I_L - I_C)^2}$</p> <p>$Z = \frac{V_T}{I_T}$</p> <p>$\cos \theta = \frac{I_R}{I_T}$</p> <p>$Q = \frac{R}{X_L} = \frac{R}{X_C}$</p>	<p>STAR</p> <p>$V_L = \sqrt{3} V_{PH}$</p> <p>$V_{PH} = I_{PH} Z_{PH}$</p> <p>$I_L = I_{PH}$</p> <p>DELTA</p> <p>$V_L = V_{PH}$</p> <p>$V_{PH} = I_{PH} Z_{PH}$</p> <p>$I_L = \sqrt{3} I_{PH}$</p> <p>POWER</p> <p>$S(P_{app}) = \sqrt{3} V_L I_L$</p> <p>$Q(P_r) = \sqrt{3} V_L I_L \sin \theta$</p> <p>$P = \sqrt{3} V_L I_L \cos \theta$</p> <p>$\cos \theta = \frac{P}{S}$</p> <p>EFFICIENCY</p> <p>$\eta = \frac{P_{OUT}}{P_{IN}} \times 100$</p> <p>TWO-WATTMETER METHOD</p> <p>$P_T = P_1 + P_2$</p> <p>$\tan \theta = \sqrt{3} \left(\frac{P_1 - P_2}{P_1 + P_2} \right)$</p> <p>THREE-WATTMETER METHOD</p> <p>$P_T = P_1 + P_2 + P_3$</p>

THREE-PHASE TRANSFORMERS	THREE-PHASE MOTORS AND STARTERS
<p>STAR $V_L = \sqrt{3} V_{PH}$ $I_L = I_{PH}$</p> <p>DELTA $V_L = V_{PH}$ $I_L = \sqrt{3} I_{PH}$</p> <p>POWER $S(P_{app}) = \sqrt{3} V_L I_L$ $Q(P_r) = \sqrt{3} V_L I_L \sin \theta$ $P = \sqrt{3} V_L I_L \cos \theta$ $\cos \theta = \frac{P}{S}$ $\frac{V_{PH(1)}}{V_{PH(2)}} = \frac{N_1}{N_2} = \frac{I_{PH(2)}}{I_{PH(1)}}$ Turns ratio: $TR = \frac{N_1}{N_2}$</p> <p>EFFICIENCY $\eta = \frac{P_{OUT}}{P_{OUT} + \text{losses}} \times 100$</p>	<p>STAR $V_L = \sqrt{3} V_{PH}$ $I_L = I_{PH}$</p> <p>DELTA $V_L = V_{PH}$ $I_L = \sqrt{3} I_{PH}$</p> <p>POWER $S(P_{app}) = \sqrt{3} V_L I_L$ $Q(P_r) = \sqrt{3} V_L I_L \sin \theta$ $P = \sqrt{3} V_L I_L \cos \theta$ $P = \sqrt{3} V_L I_L \cos \theta \eta$ $\cos \theta = \frac{P}{S}$</p> <p>EFFICIENCY $\eta = \frac{P_{IN} - \text{losses}}{P_{IN}} \times 100$ $\eta = \frac{P_{OUT}}{P_{OUT} + \text{losses}} \times 100$ $\eta = \frac{P_{OUT}}{P_{IN}} \times 100$</p> <p>SPEED (pole pairs) $p = \frac{\text{poles per phase}}{2}$ $n_s = \frac{60 f}{p}$ Per unit slip = $\frac{n_s - n_r}{n_s}$ $\% \text{ slip} = \frac{n_s - n_r}{n_s} \times 100$ $n_r = n_s(1 - \% \text{ slip})$ Slip = $n_s - n_r$</p>