



basic education

Department:
Basic Education
REPUBLIC OF SOUTH AFRICA

**NATIONAL
SENIOR CERTIFICATE**

GRADE 12

ELECTRICAL TECHNOLOGY: POWER SYSTEMS

NOVEMBER 2025

MARKING GUIDELINES

MARKS: 200

These marking guidelines consist of 17 pages.

INSTRUCTIONS TO THE MARKERS

1. All questions with multiple answers imply that any relevant, acceptable answer should be considered.
2. Calculations:
 - 2.1 All calculations must show the formulae.
 - 2.2 Substitution of values must be done correctly.
 - 2.3 All answers **MUST** contain the correct unit to be considered.
 - 2.4 Alternative methods must be considered, provided that the correct answer is obtained.
 - 2.5 Where an incorrect answer could be carried over to the next step, the first answer will be deemed incorrect. However, should the incorrect answer be carried over correctly, the marker has to re-calculate the values, using the incorrect answer from the first calculation. If correctly used, the candidate should receive the full marks for subsequent calculations.
3. This memorandum is only a guide with model answers. Alternative interpretations must be considered and marked on merit. However, this principle should be applied consistently throughout the marking session at ALL marking centres.

QUESTION 1: MULTIPLE-CHOICE QUESTIONS

- | | | |
|------|-----|-----|
| 1.1 | B ✓ | (1) |
| 1.2 | B ✓ | (1) |
| 1.3 | C ✓ | (1) |
| 1.4 | C ✓ | (1) |
| 1.5 | D ✓ | (1) |
| 1.6 | B ✓ | (1) |
| 1.7 | B ✓ | (1) |
| 1.8 | A ✓ | (1) |
| 1.9 | B ✓ | (1) |
| 1.10 | C ✓ | (1) |
| 1.11 | B ✓ | (1) |
| 1.12 | D ✓ | (1) |
| 1.13 | C ✓ | (1) |
| 1.14 | C ✓ | (1) |
| 1.15 | D ✓ | (1) |
- [15]**

QUESTION 2: OCCUPATIONAL HEALTH AND SAFETY

- 2.1 Any article or combination of articles assembled, arranged or connected which is used for converting any form of energy ✓ to performing work. ✓
OR
Any article or combination of articles which is used or intended to be used, whether incidental there to or not, for developing, receiving, storing, containing, confining, transforming, transmitting, transferring or controlling any form of energy. (2)
- 2.2 Do not touch the person with bare hands. ✓
Use a non-conductive material to free the person from the live connection. ✓
Switch off the supply (2)
- 2.3 The use/misuse of power tools without adhering to safety protocols. ✓
The etching of PC boards without following safety procedures. ✓
Working on a live system without following safety protocol. (2)
- 2.4 A *critical incident* is an event that causes grave or severe physical injury to a person that requires external emergency services. ✓
An *accident* is an event that may cause injury or damage to property (severe or not severe). ✓ (2)
- 2.5 It is an unsafe act, because it creates an unsafe condition ✓ (no guard on the machine) that is conducted by a person in a manner that may threaten the safety ✓ of people in the workshop. (2)
- [10]**

QUESTION 3: RLC CIRCUITS

3.1 3.1.1 Resonant frequency ✓ (1)

3.1.2 Quality factor/Q factor ✓ (1)

3.2 3.2.1 $V_T = \sqrt{V_R^2 + (V_L - V_C)^2}$ ✓

$$= \sqrt{202,16^2 + (226,82 - 140,18)^2}$$
 ✓
$$= 219,94 \text{ V}$$
 ✓ (3)

3.2.2 $I_T = \frac{V_T}{Z}$ ✓

$$Z = \frac{V_T}{I_T}$$
 ✓
$$= \frac{219,94}{3,61}$$
 ✓
$$= 60,93 \Omega$$
 ✓ (3)

OR

Alternatively calculate $R = 56 \Omega$ and $X_C = 31,83 \Omega$, then $Z = 64,01 \Omega$

3.2.3 $\cos\theta = \frac{V_R}{V_T}$ ✓

If R is calculated:
 $\cos\theta = \frac{R}{Z}$

$$\theta = \cos^{-1}\left(\frac{V_R}{V_T}\right)$$
 ✓
$$= \cos^{-1}\left(\frac{202,16}{219,94}\right)$$
 ✓
$$= 23,20^\circ$$
 ✓ (3)

OR $\theta = \cos^{-1}\left(\frac{56}{60,93}\right)$
 $= 23,21^\circ$

NOTE: $\tan\theta = \frac{V_L - V_C}{V_R}$ may also be used.

3.2.4 $X_C = \frac{1}{2\pi fC}$ ✓

At resonance $X_L = X_C$, therefore

$$C = \frac{1}{2\pi fX_C}$$
 ✓
$$= \frac{1}{2\pi \times 50 \times 62,83}$$
 ✓
$$= 50,66 \mu\text{F}$$
 ✓ (3)

3.3

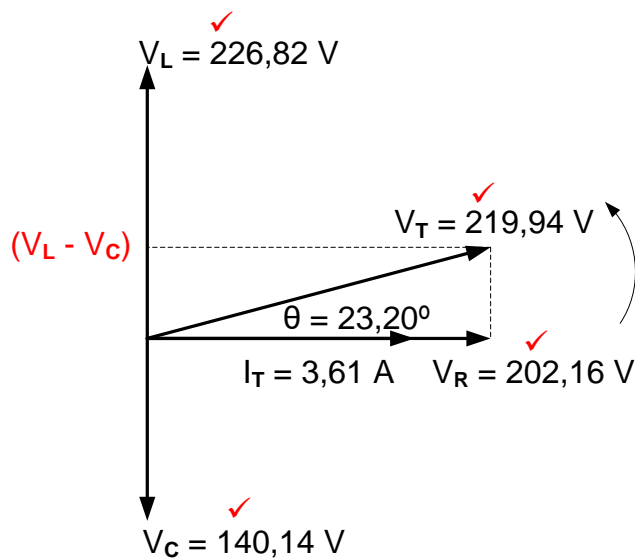

NOTE:

V_L and V_C are the TWO primary labels thereafter any TWO correct labels. If V_L , V_C , V_R , V_T , θ and $(V_L - V_C)$ are written without values, marks will be awarded given there is a distinct difference between the length of the phasors.

(4)

3.4

3.4.1

$$I_T = \sqrt{I_R^2 + (I_L - I_C)^2}$$

$$= \sqrt{0,5^2 + (0,9 - 0,2)^2}$$

$$= 0,86 \text{ A}$$

✓
✓
✓

(3)

3.4.2

$$X_C = \frac{V_T}{I_C}$$

$$= \frac{50}{0,2}$$

$$= 250 \Omega$$

✓
✓
✓

(3)

3.5

The circuit is more inductive. ✓ The inductive current I_L is greater than the capacitive current I_C . ✓

(2)

3.6

When the frequency increases X_C decreases ✓ and X_L increases ✓ until they are both equal ✓ and the circuit will resonate. When the frequency increases, I_C increases and I_L decreases until they are both equal and the circuit will resonate.

(3)

3.7

3.7.1

Parallel RLC circuit. ✓ Impedance is maximum ✓ at resonance in a parallel RLC circuit.

(2)

$$3.7.2 \quad BW = \frac{f_r}{Q} \quad \checkmark$$

$$\therefore BW = f_2 - f_1 \quad \checkmark$$

$$(9200 - 5400) = \frac{7300}{Q} \quad \checkmark$$

$$Q = \frac{7300}{(9200 - 5400)} \quad \checkmark$$

$$= 1,92$$

(4)
[35]**QUESTION 4: THREE-PHASE AC GENERATION**

- 4.1
- Installations costs are very high. \checkmark
 - Appliances using three phase power supply are very expensive. \checkmark
 - Three-phase power supply voltage is not available everywhere,
 - Not suitable for most residential applications. (2)

- 4.2 A power factor of less than 1 means that the voltage and current waveforms are not in phase, \checkmark reducing the instantaneous product of the two waveforms \checkmark (effective power delivered). (2)

- 4.3 4.3.1 Delta \checkmark (1)

- 4.3.2 400 V \checkmark (1)

4.3.3

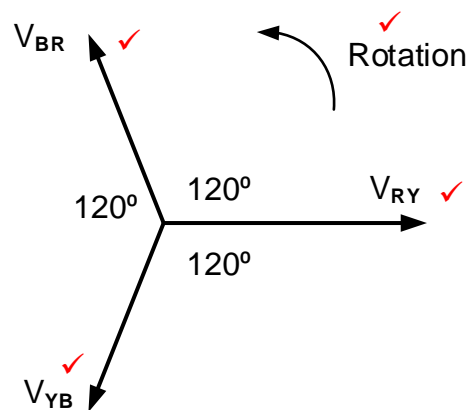
**NOTE:**

The following labels will be accepted given the sequence is correct:
 L_1, L_2 & L_3 , V_{L1}, V_{L2} & V_{L3} and R, Y & B

If the rotation label is omitted that mark may be awarded to the 120° . (4)

- 4.4 4.4.1 $V_L = \sqrt{3}V_{PH} \quad \checkmark$
- $$= \sqrt{3} \times 220 \quad \checkmark$$
- $$= 381,05 V \quad \checkmark$$
- (3)

$$\begin{aligned}
 4.4.2 \quad S &= \sqrt{3} V_L I_L && \checkmark \\
 I_L &= \frac{S}{\sqrt{3} V_L} && \checkmark \\
 &= \frac{16\,000}{\sqrt{3} \times 381,05} && \checkmark \\
 &= 24,24 \text{ A} && \checkmark
 \end{aligned}
 \tag{3}$$

$$\begin{aligned}
 4.4.3 \quad P &= \sqrt{3} V_L I_L \cos\theta && \checkmark \\
 &= \sqrt{3} \times 381,05 \times 24,24 \times \cos(29,54) && \checkmark \\
 &= 13\,918,75 \text{ W} && \checkmark \\
 &= 13,92 \text{ kW} && \checkmark
 \end{aligned}
 \tag{3}$$

OR

$$\begin{aligned}
 P &= S \cos\theta \\
 &= 16\,000 \times \cos(29,54) \\
 &= 13\,920,19 \text{ W} \\
 &= 13,92 \text{ kW}
 \end{aligned}$$

$$\begin{aligned}
 4.4.4 \quad Q &= \sqrt{3} V_L I_L \sin\theta && \checkmark \\
 &= \sqrt{3} \times 381,05 \times 24,24 \times \sin(29,54) && \checkmark \\
 &= 7887,68 \text{ VAr} && \checkmark \\
 &= 7,89 \text{ kVAr} && \checkmark
 \end{aligned}
 \tag{3}$$

OR

$$\begin{aligned}
 Q^2 &= S^2 - P^2 \\
 Q &= \sqrt{16\,000^2 - 13\,920,19^2} \\
 &= 7888,49 \text{ VAr} \\
 &= 7,89 \text{ kVAr}
 \end{aligned}$$

$$\begin{aligned}
 4.5 \quad \eta &= \frac{P_{OUT}}{P_{IN}} \times 100 && \checkmark \\
 &= \frac{3\,200}{3\,450} \times 100 && \checkmark \\
 &= 92,75\% && \checkmark
 \end{aligned}
 \tag{3}$$

- 4.6 4.6.1 Coil A - Current coil. ✓ (1)
- 4.6.2 Digital wattmeters:
 • Eliminates the need for precise mechanical components ✓
 • Reduces the need for calibration ✓
 • Can display multiple current, voltage and power readings on one device
 • Are more accurate (eliminate parallax errors)
 • Are easier to read than analogue meters (2)
- 4.6.3 Coil B is the potential coil connected in parallel with the load to measure voltage. ✓ It is movable with a needle on it and when connected it will create a magnetic field that interacts with the magnetic field on the current coil ✓ and moves/deflects to indicate a reading. (2)
- 4.7 4.7.1 Higher energy losses ✓
 Thicker cables are required ✓
 Larger switchgear is required
 Higher electricity bills (2)
- 4.7.2 A power factor meter indicates whether a system is more inductive or more capacitive. ✓
 A power factor meter indicates the ratio of the active/real power to the apparent power of an electrical system.
 To measure power factor. (1)
- 4.7.3 A load with a low power factor draws more current ✓ than a load with a high power factor because more apparent power is needed to supply the same real power. ✓ (2)
- [35]**

QUESTION 5: THREE-PHASE TRANSFORMERS

- 5.1 When an alternating voltage is applied to the primary winding, alternating flux is set up in the core, ✓ which links with the secondary winding and induces an emf ✓ of the same frequency to the secondary. (2)
- 5.2 5.2.1 $A_1 - A_3$ windings are connected in star configuration. ✓
 $B_1 - B_3$ windings are connected in delta configuration. ✓ (2)
- 5.2.2 An iron core is needed in the construction of a transformer to provide a magnetic field intense enough ✓ to produce the rated voltage ✓ in the windings with a minimum of exciting current. ✓
 OR
 To strengthen the magnetic coupling in the process of transferring power from the primary to the secondary winding. (3)
- 5.2.3 It is a Core type. ✓
 The core is surrounded by the windings. ✓
 The core has three limbs (2)

- 5.2.4 Dry type transformers dissipate heat through a tubular radiator around which air circulates, ✓ keeping the transformer cool. (1)
- 5.3 5.3.1 Voltage rating ✓
Current rating
Turns ratio
Power rating
Efficiency (1)
- 5.3.2 It is used as step-down transformers in distribution systems ✓ where a four-wire system (neutral) is required.
School, hospital, Industry etc. will be accepted. (1)
- 5.3.3 The cost of replacing one damaged transformer is less ✓ as compared to replacing the whole three-phase transformer unit. ✓

If one transformer (one-phase) becomes faulty, the faulty unit can be removed and replaced without replacing the entire system. (2)
- 5.4 5.4.1 In delta $V_L = V_{PH}$ ✓
 $\therefore V_L = V_{PH} = 6\,600\text{ V}$ ✓ (2)
- 5.4.2 $V_L = \sqrt{3}V_{PH(2)}$ ✓
 $V_{PH(2)} = \frac{V_L}{\sqrt{3}}$ ✓
 $= \frac{380}{\sqrt{3}}$ ✓
 $= 219,39\text{ V}$ ✓ (3)
- 5.4.3 $TR = \frac{N_1}{N_2} = \frac{V_{PH(1)}}{V_{PH(2)}}$ ✓
 $= \frac{6\,600}{219,39}$ ✓
 $= 30,08 : 1$ ✓
 $= 30 : 1$ (3)
- 5.4.4 $\frac{V_{PH(1)}}{V_{PH(2)}} = \frac{I_{PH(2)}}{I_{PH(1)}}$ ✓
 $I_{PH(1)} = \frac{V_{PH(2)}I_{PH(2)}}{V_{PH(1)}}$ ✓
 $= \frac{219,92 \times 900}{6\,600}$ ✓
 $= 29,92\text{ A}$ (3)

$$5.5 \quad \eta = \frac{P_{OUT}}{P_{OUT} + losses} \times 100 \quad \checkmark$$

$$losses = \frac{P_{OUT}}{\eta} - P_{OUT}$$

$$= \frac{4\,500}{0,96} - 4\,500 \quad \checkmark$$

$$= 187,50 \text{ W} \quad \checkmark$$

(3)

- 5.6 A conservator is required to allow for the expansion and contraction \checkmark of the oil during changes of the temperatures with different operating loads \checkmark or changing of the surrounding air temperature. \checkmark

(2)
[30]

QUESTION 6: THREE-PHASE MOTORS AND STARTERS

- 6.1 Resistance/continuity test of the windings. ✓
Insulation resistance test between windings. ✓
Insulation resistance test between windings and earth. (2)
- 6.2 The reactive power of a three-phase induction motor is the power used to set up and maintain the electromagnetic field in the stator, ✓ without doing any real work. ✓ (2)
- 6.3 6.3.1 A - Locked rotor torque ✓
Starting/Start-up torque
B - Breakdown torque ✓ (2)
- 6.3.2 The slip is minimum at no-load speed. ✓ (1)
- 6.4 6.4.1 $n_s = \frac{60f}{p}$ ✓
 $= \frac{60 \times 50}{2}$ ✓
 $= 1500 \text{ r/min}$ ✓ (3)
- 6.4.2 % Slip = $\frac{n_s - n_r}{n_s} \times 100$ ✓
 $= \frac{1500 - 1250}{1500} \times 100$ ✓
 $= 16,67\%$ ✓ (3)
- 6.5 6.5.1 $\cos\theta = pf$ ✓
 $\cos\theta = 0,85$ ✓
 $\theta = \cos^{-1}(0,85)$ ✓
 $= 31,79^\circ$ ✓ (3)
- 6.5.2 $P = \sqrt{3}V_L I_L \cos\theta$ ✓
 $V_L = \frac{P}{\sqrt{3}I_L \cos\theta}$ ✓
 $= \frac{4000}{\sqrt{3} \times 6,8 \times 0,85}$ ✓
 $= 399,55 \text{ V}$ (3)
- 6.5.3 $S = \sqrt{3} V_L I_L$ ✓
 $= \sqrt{3} \times 399,55 \times 6,8$ ✓
 $= 4705,88 \text{ VA}$ ✓
 $= 4,71 \text{ kVA}$ ✓
- OR $\cos\theta = \frac{P}{S}$
 $S = \frac{P}{\cos\theta}$
 $S = \frac{4000}{0,85}$
 $S = 4,71 \text{ kVA}$

$$\begin{aligned}
 6.5.4 \quad Q &= \sqrt{3} V_L I_L \sin\theta && \checkmark \\
 &= \sqrt{3} \times 399,55 \times 6,8 \times \sin(31,79) && \checkmark \\
 &= 2479,09 \text{ VA}_R && \checkmark \\
 &= 2,48 \text{ kVA}_R && \checkmark
 \end{aligned}$$

(3)

OR

$$\begin{aligned}
 S^2 &= P^2 + Q^2 \\
 Q &= \sqrt{S^2 - P^2} \\
 &= \sqrt{4705,88^2 - 4000^2} \\
 &= 2478,97 \text{ VA}_r \\
 &= 2,48 \text{ kVA}_r
 \end{aligned}$$

- 6.6 6.6.1 MC₁N/O \checkmark
Retain / hold-in contact (1)
- 6.6.2 OL N/C will open when the current drawn by the motor in the main circuit exceeds the set value (or when the motor is overloaded). \checkmark (1)
- 6.6.3 One contactor will be used to provide power to the motor for forward rotation. \checkmark The other contactor will be used to swop any of the two power lines to the motor in order for it to reverse its rotation. \checkmark (2)
- 6.6.4 Interlocking \checkmark (1)

6.6.5

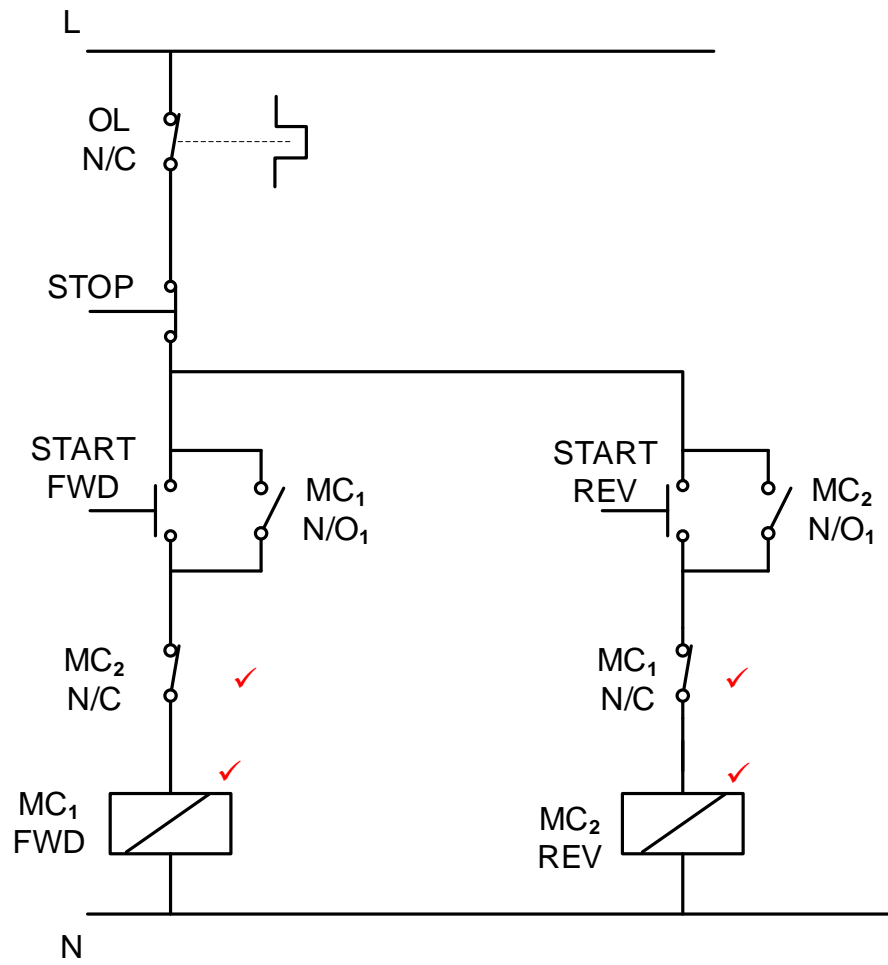

(4)

6.6.6 The circuit will not be energized ✓ when any of the start buttons is pressed.

(1)
[35]

QUESTION 7: PROGRAMMABLE LOGIC CONTROLLERS (PLCs)

- 7.1 7.1.1 A = Input Scan/Read inputs ✓
 B = Process scan/Run programme ✓ (2)
- 7.1.2 The PLC updates the status of all output devices ✓ based on the results of the program execution. ✓ (2)
- OR
- The PLC finally activates each of the outputs connected to it, according to the status of the 'output table' stored in memory. (2)
- 7.2 • A PLC system becomes more economical (cheaper) when compared to large, bulky relay systems. ✓
 • Modifications are less expensive as the program can merely be altered instead of replacing/adding components in hardwired relay systems. ✓ (2)
- 7.3 To ensure that:
 • There is no incorrect wiring ✓ that could cause short circuits and damage the PLC unit.
 • There are no loose connections ✓ that can cause false triggering or arcing. (2)
- 7.4 • All processing is done at low voltages and therefore safer. ✓
 • The normal operation of a plant can be observed electronically on a monitor keeping the observer away from dangerous machines. ✓
 • All operations are shown on the interface as machines turned on and faulty contactors can be located without having to fault find on a live system.
 • Part of a plant can be switched off digitally for repairs to be done. (2)
- 7.5 7.5.1 • Markers are used to hold data ✓ in the PLC program.
 • They can be switched on or off and control other programs or output devices. ✓
 • They can be used to indicate when a certain stage in a program is complete.
 • They can be used to indicate the start of the timing processors next event. (2)
- 7.5.2 • The contactor in a program drives the coil of the relay contact on the output module. ✓
 • It can be programmed to be normally closed or normally open contacts. ✓
 • When a contactor in a program is activated, it is an indication that a rung is successfully completed. (2)

7.6 7.6.1

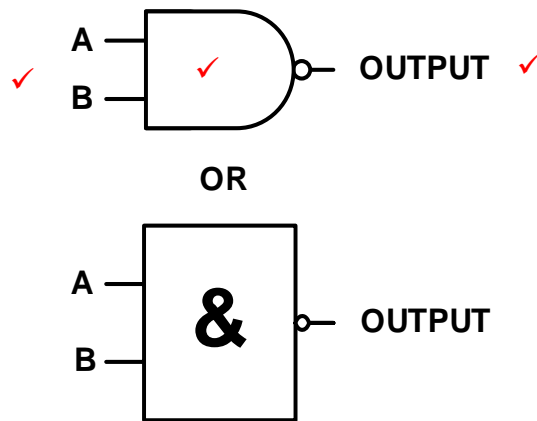

NOTE:

Marks can only be awarded to the labels if the symbol is correct

(3)

7.6.2 X = 1 ✓
Y = 0 ✓

(2)

7.7

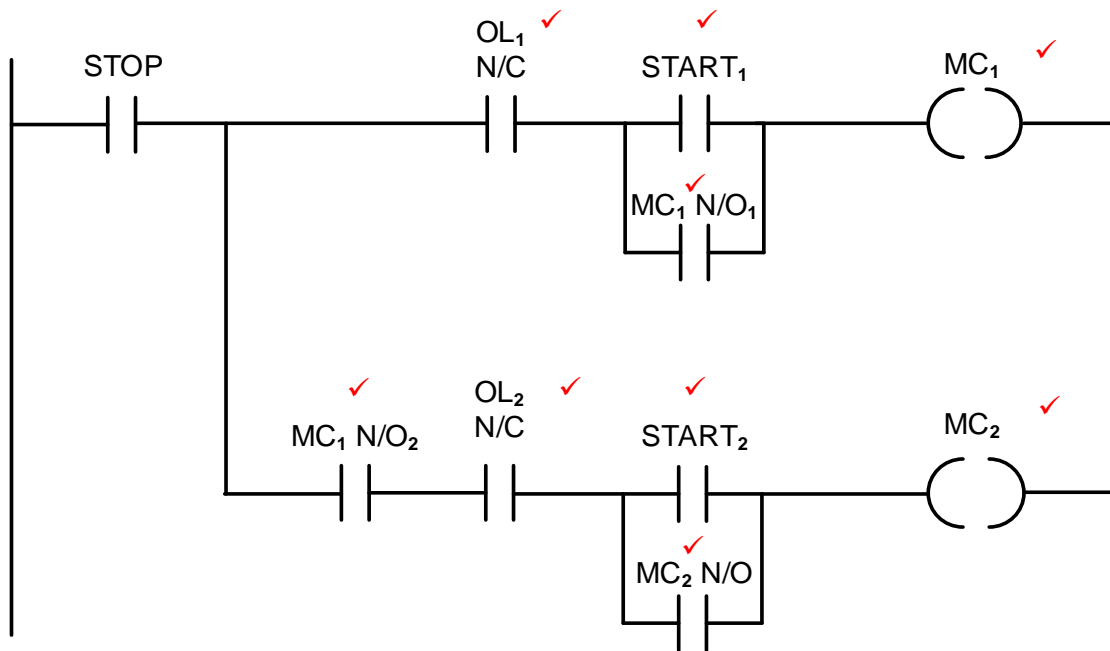

(9)

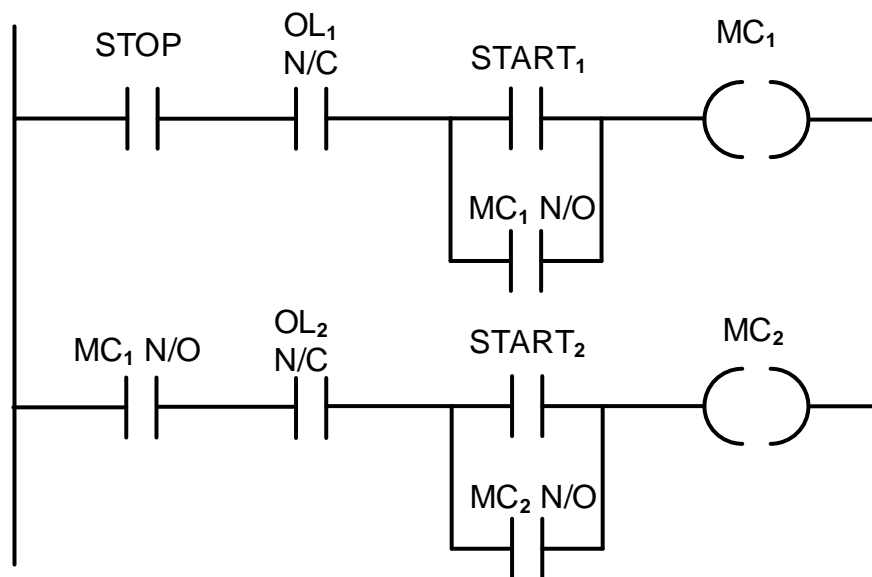

- 7.8 7.8.1 Improvement of torque ✓ over the same current drawn. ✓ (2)
- 7.8.2
- Improves energy usage by controlling the power that is fed into the motor. ✓
 - Reduce motor wear. ✓
 - Better process control, such as speeding up or slowing down a motor process depending on the type of production and processes.
 - It can convert a fixed-frequency and fixed voltage to a variable frequency and variable voltage.
 - The VSD requires less current to provide the required torque to a specific load and thus the motor can be under designed with thinner wires, leading to a cheaper motor and more profit. (2)
- 7.9 Braking Resistor. ✓ (1)
- 7.10
- Variable air volume air conditioning system ✓
 - Exhaust systems ✓
 - Water pumping systems ✓
 - Fan systems
 - Heating systems
 - Battery powered electric cars (3)
- 7.11 A VSD has a rectifier that changes the three-phase AC supply to DC by using three pairs of diodes ✓ where each pair of diodes rectifies a phase of the three-phase supply. ✓ (2)
- 7.12 Longer ON times during pulse width modulation creates a longer waveform ✓ which in turn decreases the frequency of the VSD output. ✓ (2)

[40]**TOTAL: 200**