

*Confidential*



# basic education

Department:  
Basic Education  
**REPUBLIC OF SOUTH AFRICA**

**NATIONAL  
SENIOR CERTIFICATE**

**GRADE 12**

**ELECTRICAL TECHNOLOGY: ELECTRONICS**

**NOVEMBER 2025**

**MARKS: 200**

**TIME: 3 hours**

**This question paper consists of 25 pages, a 2-page formula sheet and  
a 6-page answer sheet.**

**INSTRUCTIONS AND INFORMATION**

1. This question paper consists of SIX questions.
2. Answer ALL the questions.
3. Answer the following questions on the attached ANSWER SHEETS:  
  
QUESTIONS 4.2, 4.5 and 4.11  
QUESTIONS 5.2.3, 5.3.2, 5.3.4 and 5.4.4  
QUESTION 6.3.5
4. Write your centre number and examination number on every ANSWER SHEET and hand them in with your ANSWER BOOK, whether you have used them or not.
5. Sketches and diagrams must be large, neat and FULLY LABELLED.
6. Show ALL calculations and round off answers correctly to TWO decimal places.
7. Number the answers correctly according to the numbering system used in this question paper.
8. You may use a non-programmable calculator.
9. Calculations must include:
  - 9.1 Formulae and manipulations where needed
  - 9.2 Correct replacement of values
  - 9.3 Correct answer and relevant units where applicable
10. A formula sheet is attached at the end of this question paper.
11. Write neatly and legibly.

**QUESTION 1: MULTIPLE-CHOICE QUESTIONS**

Various options are provided as possible answers to the following questions. Choose the answer and write only the letter (A–D) next to the question numbers (1.1 to 1.15) in the ANSWER BOOK, e.g. 1.16 D.

- 1.1 A/An ... provides work for another person and remunerates that person.  
A employee  
B employer  
C supervisor  
D health and safety representative (1)
- 1.2 The phase difference between the voltage across the capacitor and the voltage across the resistor in an RC series circuit is ...  
A 0°  
B 90°  
C 120°  
D 180° (1)
- 1.3 In an RLC series circuit, the total current lags the supply voltage. This is an indication that the frequency is ... resonance.  
A below  
B equal to  
C above (1)
- 1.4 The total impedance in an RLC parallel circuit with a variable frequency supply is equal to the ... at resonance.  
A inductive reactance  
B capacitive reactance  
C resistance (1)
- 1.5 The advantage of a field-effect transistor is that ...  
A it has a high input resistance.  
B it has a low input resistance.  
C it draws a high current from a circuit to which it is coupled.  
D None of the above-mentioned (1)
- 1.6 The ... is one of the UJT characteristic operating regions.  
A emitter region  
B positive resistance region  
C forward region  
D negative resistance region (1)

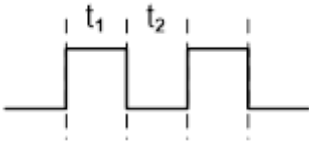
- 1.7 The ... controls the closed-loop gain of an operational amplifier circuit.
- A power supply voltage
  - B internal structure of the op amp
  - C components in the feedback network
  - D type of input signal applied
- (1)
- 1.8 The voltage that must be applied on pin 2 to allow the output of 555 IC to go 'low' is ...
- A 1/3 of the supply voltage.
  - B 2/3 of the supply voltage.
  - C less than 1/3 of the supply voltage.
  - D greater than 2/3 of the supply voltage.
- (1)
- 1.9 The ... produces one pulse cycle of high and low when a trigger pulse is applied to its input.
- A astable multivibrator
  - B monostable multivibrator
  - C bistable multivibrator
  - D comparator
- (1)
- 1.10 The following output signal produced by an op amp astable multivibrator has a duty cycle of ... when  $t_1 = t_2$ .
- 
- A 25%
- B 50%
- C 75%
- D 100%
- (1)
- 1.11 The ... is used to recover a signal after it has suffered severe distortion.
- A inverting comparator
  - B op amp differentiator
  - C Schmitt trigger
  - D summing amplifier
- (1)

- 1.12 The following is/are key in the operation of an op amp integrator circuit:
- A The inputs of the op amp draw zero current.
  - B The two inputs of the op amp are viewed as both always possessing the same voltage.
  - C When a constant current is fed to the capacitor, it will charge at a constant fixed rate.
  - D All the above-mentioned (1)
- 1.13 A ... amplifier has a conduction angle of less than 180° of the input cycle.
- A class A
  - B class B
  - C class AB
  - D class C (1)
- 1.14 Identify the oscillator that is used in signal generators above 1 MHz because of good frequency stability:
- A Hartley
  - B Colpitts
  - C RC phase-shift (1)
- 1.15 When the voltage gain of an amplifier is increased, the bandwidth ...
- A is not affected.
  - B increases.
  - C decreases.
  - D becomes distorted. (1)
- [15]**

## QUESTION 2: OCCUPATIONAL HEALTH AND SAFETY

- 2.1 Explain *machinery* with reference to the Occupational Health and Safety Act, 1993 (Act 85 of 1993). (2)
- 2.2 State TWO precautionary measures to protect yourself when assisting someone that has been electrocuted. (2)
- 2.3 Give TWO examples of dangerous practices in the electrical workshop. (2)
- 2.4 Differentiate between a *critical incident* and an *accident*. (2)
- 2.5 In the electrical workshop, you saw one of your classmates removing a safety guard on a machine. According to the Occupational Health and Safety Act, 1993 (Act 85 of 1993), this is an unsafe act. Motivate why it is an unsafe act. (2)
- [10]**

**QUESTION 3: RLC CIRCUITS**

3.1 With reference to RLC circuits, state the correct terminology that describes the following:

3.1.1 The frequency at which  $X_L$  is equal to  $X_C$  (1)

3.1.2 The ratio of the energy stored to the energy converted by an inductor or capacitor (1)

3.2 FIGURE 3.2 below shows an RLC series circuit connected to an AC supply. Answer the questions that follow.

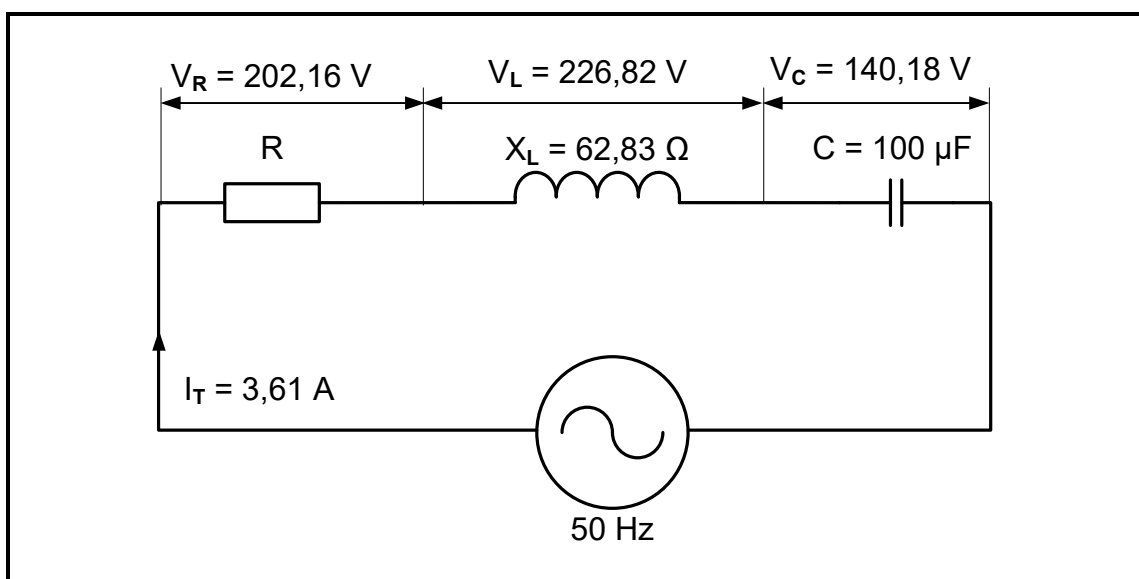

**FIGURE 3.2: RLC SERIES CIRCUIT**

Given:

$I_T$	= 3,61 A
$X_L$	= 62,83 $\Omega$
$C$	= 100 $\mu\text{F}$
$V_R$	= 202,16 V
$V_L$	= 226,82 V
$V_C$	= 140,18 V
$f$	= 50 Hz

Calculate the following:

3.2.1 Supply voltage (3)

3.2.2 Impedance (3)

3.2.3 Phase angle (3)

3.2.4 Capacitance value that will cause resonance (3)

3.3 Redraw and complete the voltage phasor diagram of QUESTION 3.2 in FIGURE 3.3 below in the ANSWER BOOK.

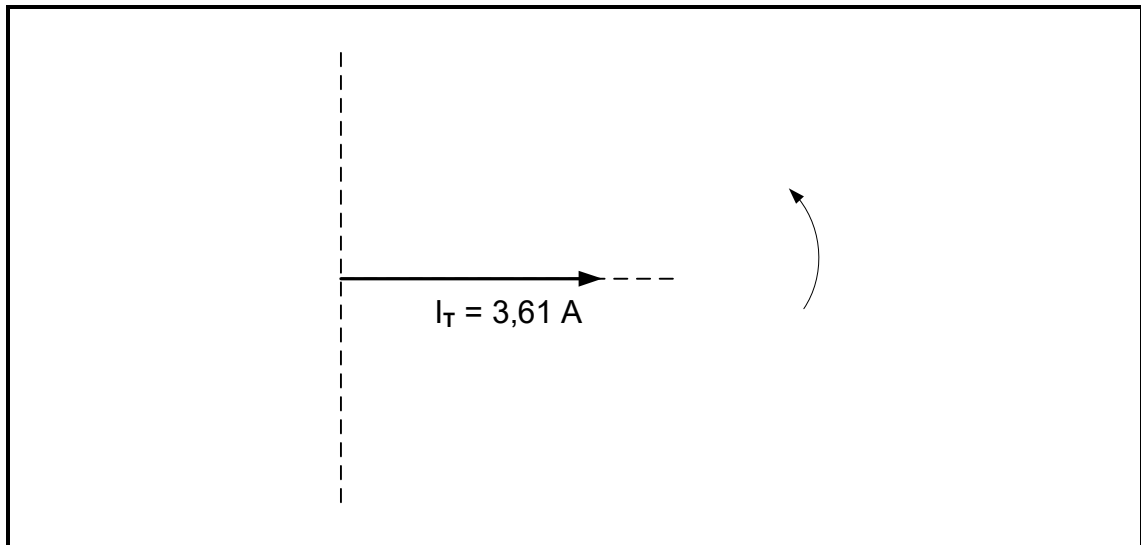

**FIGURE 3.3: INCOMPLETE VOLTAGE PHASOR DIAGRAM**

(4)

3.4 FIGURE 3.4 below shows an RLC parallel circuit with its corresponding phasor diagram. Answer the questions that follow.

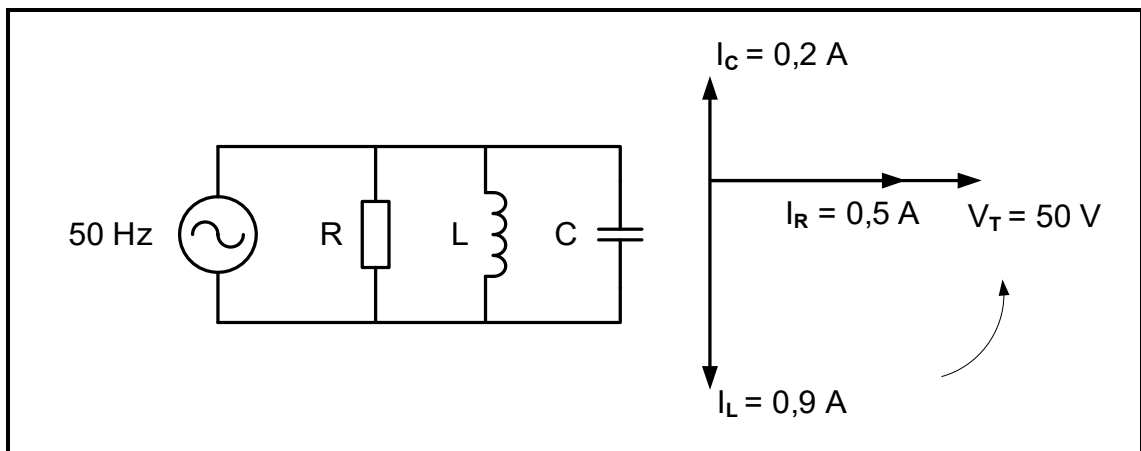

**FIGURE 3.4: RLC PARALLEL CIRCUIT AND PHASOR DIAGRAM**

Given:

- $V_T = 50 \text{ V}$
- $I_R = 0,5 \text{ A}$
- $I_L = 0,9 \text{ A}$
- $I_C = 0,2 \text{ A}$
- $f = 50 \text{ Hz}$

Calculate the following:

3.4.1 Total current (3)

3.4.2 Capacitive reactance (3)

- 3.5 State whether the circuit in FIGURE 3.4 on the previous page is more capacitive or more inductive. Give a reason for the answer. (2)
- 3.6 Refer to FIGURE 3.4 on the previous page and explain how an increase in the supply frequency will cause the circuit to resonate. (3)
- 3.7 FIGURE 3.7 below shows the frequency response curve of an RLC circuit, NOT to scale. Answer the questions that follow.

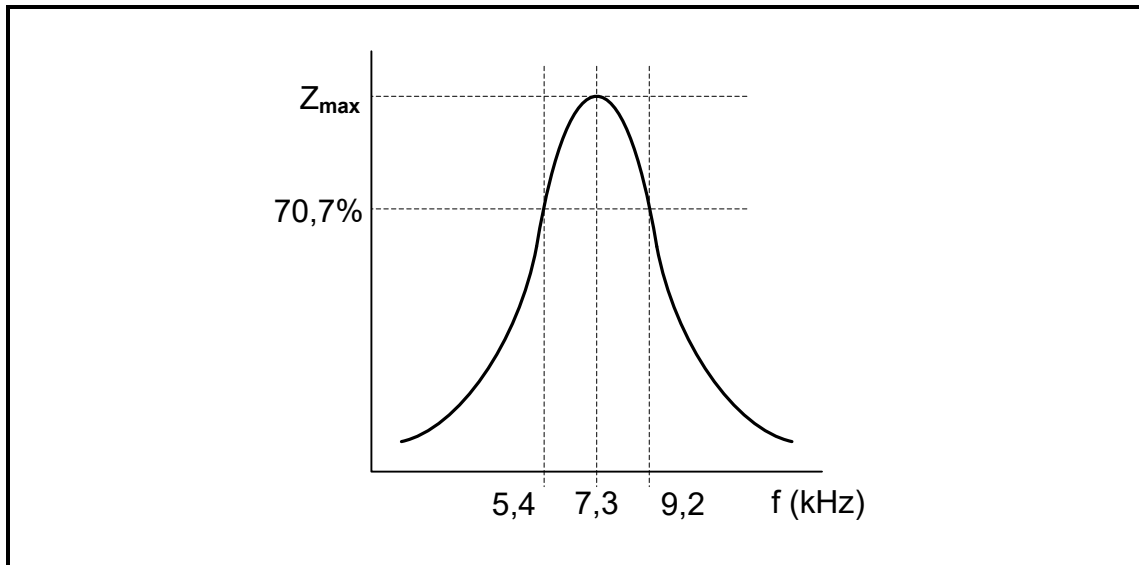

**FIGURE 3.7: Q-FACTOR CHARACTERISTIC CURVE**

- 3.7.1 State whether FIGURE 3.7 above represents the response curve for a series or parallel RLC circuit and motivate the answer. (2)
- 3.7.2 Calculate the Q-factor of the circuit. (4)

**[35]**

**QUESTION 4: SEMICONDUCTOR DEVICES**

4.1 Refer to FIGURE 4.1 below and answer the questions that follow.

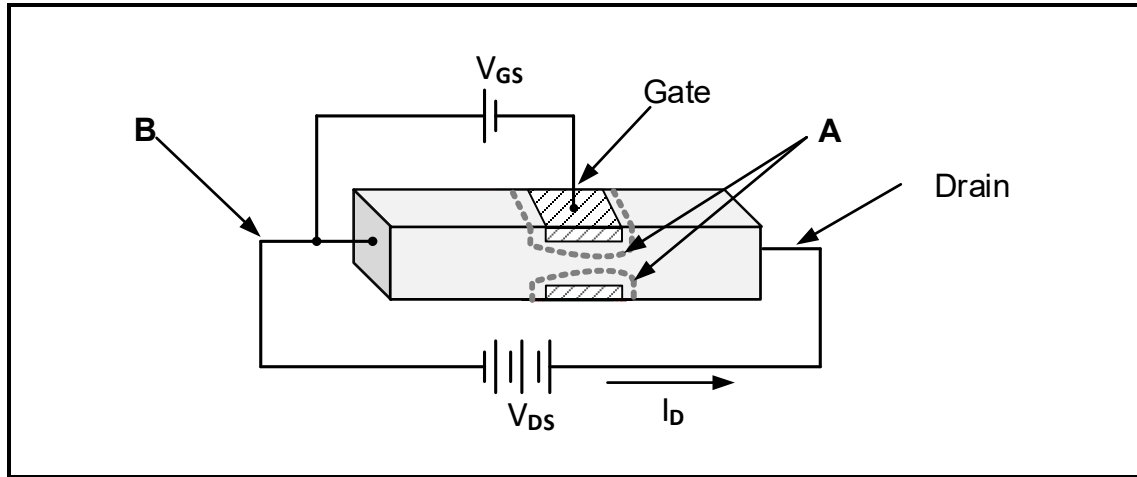

**FIGURE 4.1**

- 4.1.1 Identify FIGURE 4.1 above. (1)
- 4.1.2 Label **A** and **B**. (2)
- 4.1.3 Explain why the negative terminal of  $V_{GS}$  is connected to the gate in FIGURE 4.1 above. (1)
- 4.1.4 Explain how a decrease in  $V_{GS}$  would affect the drain current ( $I_D$ ). (2)

4.2 Refer to FIGURE 4.2 below and complete the output characteristic of a JFET on the ANSWER SHEET for QUESTION 4.2 and label it.

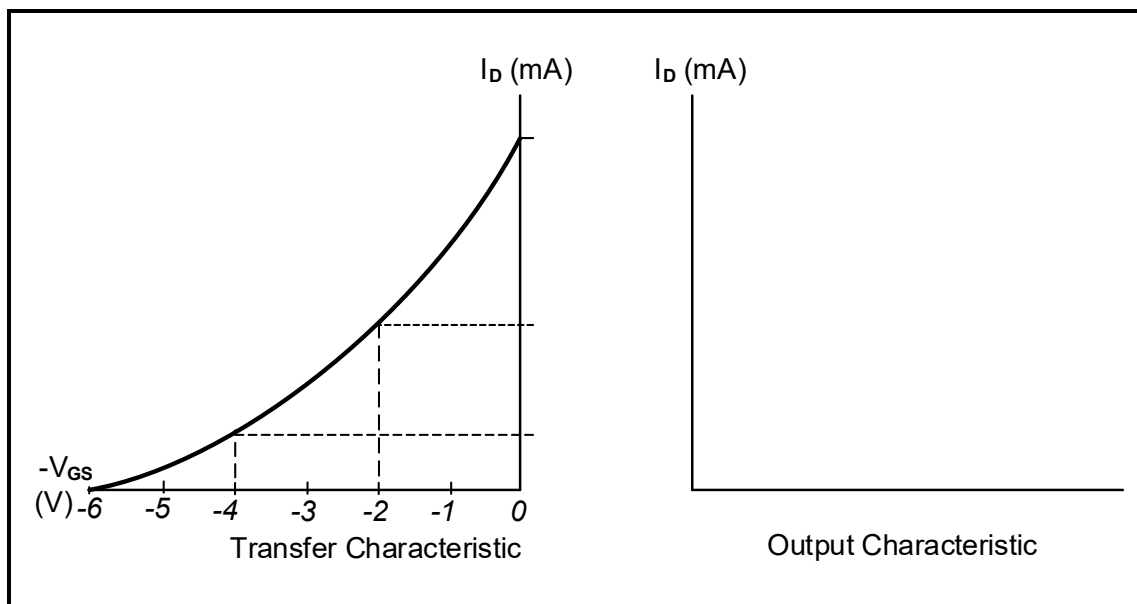

**FIGURE 4.2: INCOMPLETE OUTPUT CHARACTERISTIC OF A JFET**

(4)

4.3 FIGURE 4.3 below shows a cross-section of a semiconductor. Answer the questions that follow.

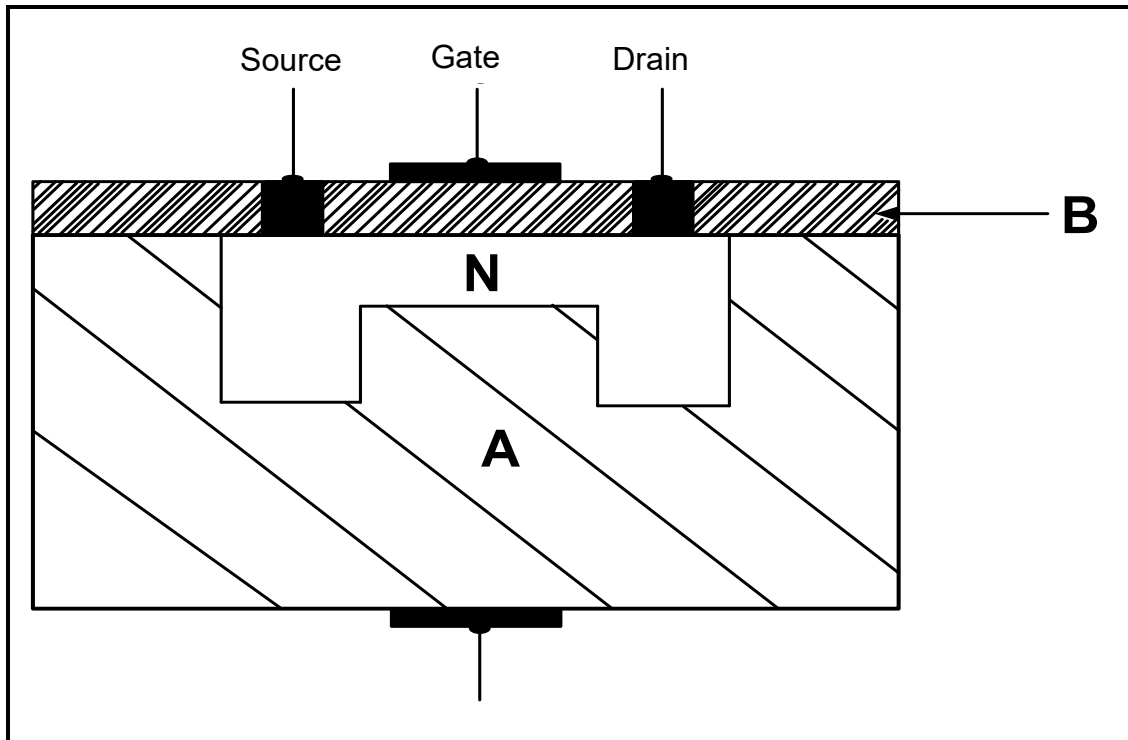

**FIGURE 4.3: CROSS-SECTION OF A SEMICONDUCTOR**

4.3.1 Identify the semiconductor. (1)

4.3.2 Label **A** and **B**. (2)

4.3.3 Explain why the gate terminal is electrically insulated. (2)

4.4 Explain, with reference to the construction, how the MOSFET differs from the JFET. (2)

4.5 Refer to FIGURE 4.5 below and complete the circuit diagram of a fully labelled UJT as a saw-tooth generator on the ANSWER SHEET for QUESTION 4.5.

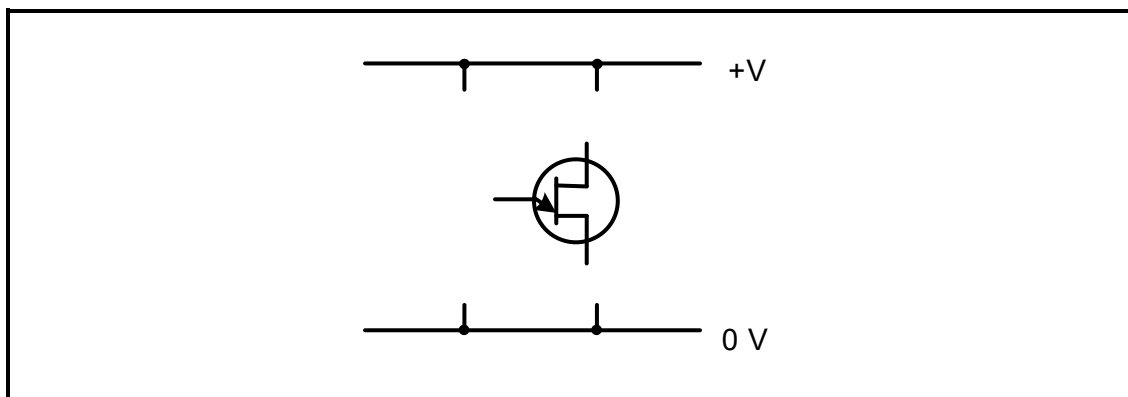

**FIGURE 4.5: INCOMPLETE CIRCUIT OF A UJT AS A SAW-TOOTH GENERATOR**

(5)

- 4.6 Draw a fully labelled symbol of a Darlington transistor. (2)
- 4.7 State why the Darlington transistor is mainly used in switching and amplification applications. (1)
- 4.8 Refer to FIGURE 4.8 below and answer the questions that follow.

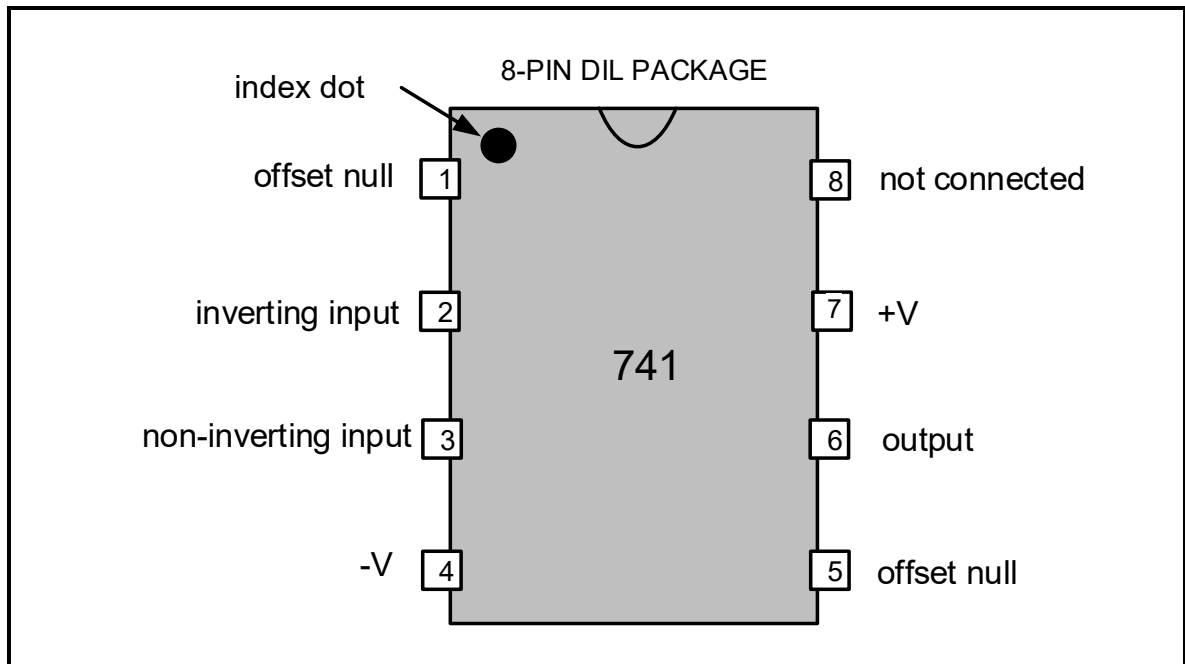

**FIGURE 4.8: 741 OP AMP**

- 4.8.1 State the purpose of the index dot on the 741 IC in FIGURE 4.8 above. (1)
- 4.8.2 Describe the effect the op amp will have on a sine wave applied to pin 2 in FIGURE 4.8 above. (2)
- 4.8.3 Explain why a 741 op amp requires a dual-rail power supply. (2)
- 4.9 Name the 741 op amp circuit that uses 100% feedback. (1)
- 4.10 The internal circuit of the 741 op amp consists of three stages, namely input stage, intermediate stage and output stage. Explain the function of the intermediate stage. (2)

4.11 Refer to FIGURE 4.11 below and complete the circuit diagram of a 741 op amp used as an inverting amplifier on the ANSWER SHEET for QUESTION 4.11.

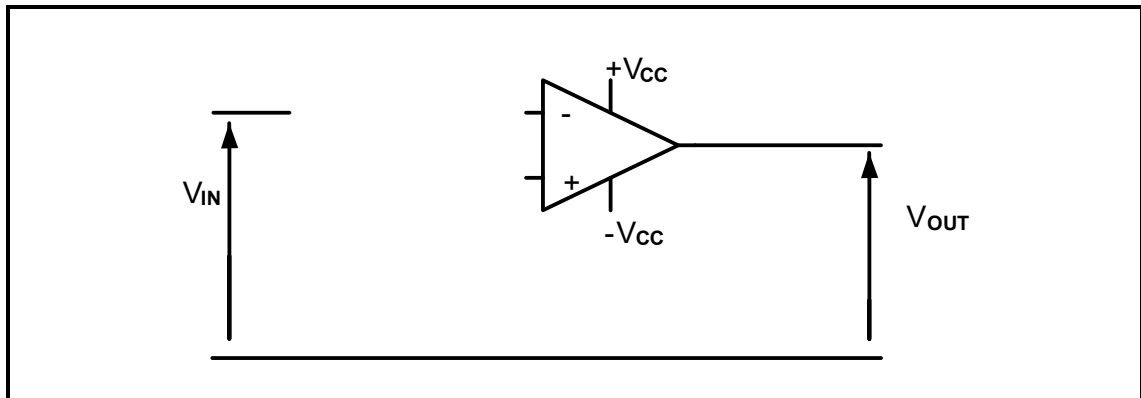

FIGURE 4.11

(3)

4.12 FIGURE 4.12 below shows the internal layout of a 555 IC. Answer the questions that follow.

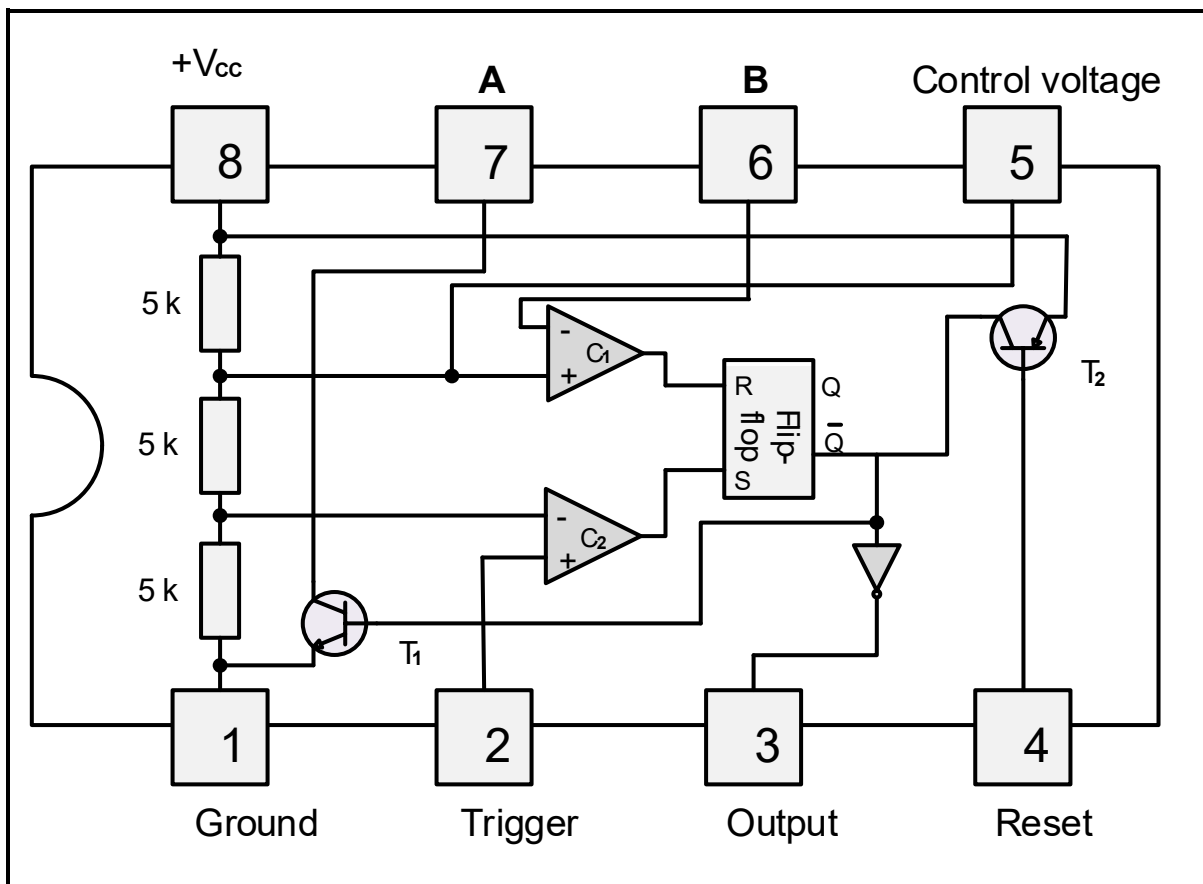

FIGURE 4.12: INTERNAL LAYOUT OF A 555 IC

4.12.1 Label **A** and **B**.

(2)

4.12.2 Explain why the RS flip-flop in FIGURE 4.12 above is also known as a memory cell.

(2)

- 4.12.3 Explain why pin 4 is normally connected to the positive supply voltage during operation. (2)
- 4.12.4 Explain how unwanted noise from the supply can be eliminated during the operation of the 555 IC. (2)
- 4.12.5 Name ONE operating mode of a 555 IC. (1)
- [45]**

**QUESTION 5: SWITCHING CIRCUITS**

5.1 Refer to op amps as switching circuits and answer the questions that follow.

5.1.1 Name ONE op amp switching circuit that operates in open-loop mode. (1)

5.1.2 With reference to the inputs of an op amp, explain the term *reference voltage*. (2)

5.2 FIGURE 5.2 below shows a bistable multivibrator circuit with a 555 IC. Answer the questions that follow.

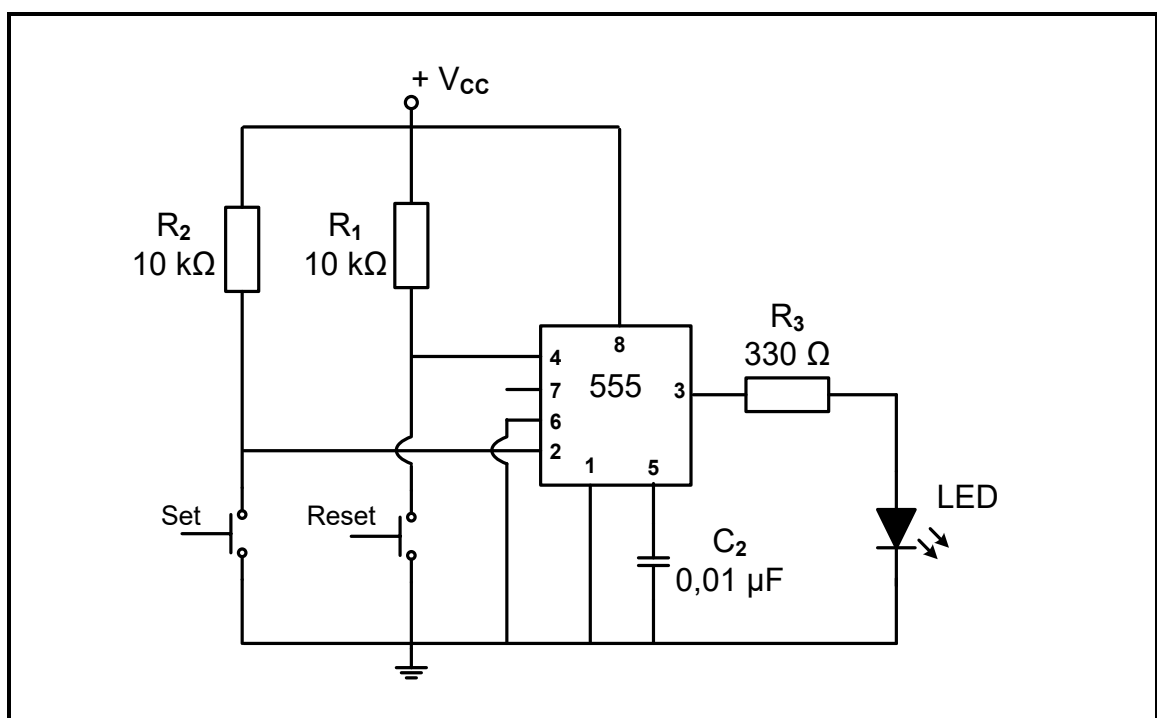
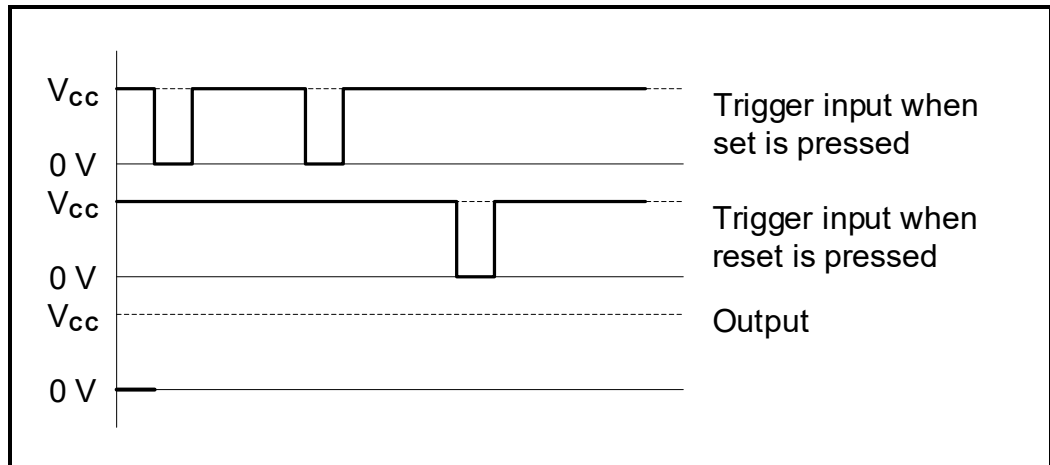

**FIGURE 5.2: BISTABLE MULTIVIBRATOR**

5.2.1 Explain the purpose of resistors  $R_1$  and  $R_2$  with reference to pins 2 and 4 when the set and reset switches are open. (2)

5.2.2 Explain what would happen if resistors  $R_1$  and  $R_2$  are bypassed with pins 2 and 4 directly connected to the supply. (2)

5.2.3 Refer to FIGURE 5.2.3 below and complete the output signal for the circuit in FIGURE 5.2 on the previous page on the ANSWER SHEET for QUESTION 5.2.3.



**FIGURE 5.2.3: BISTABLE INPUT**

(4)

5.3 Refer to FIGURE 5.3 below and answer the questions that follow.

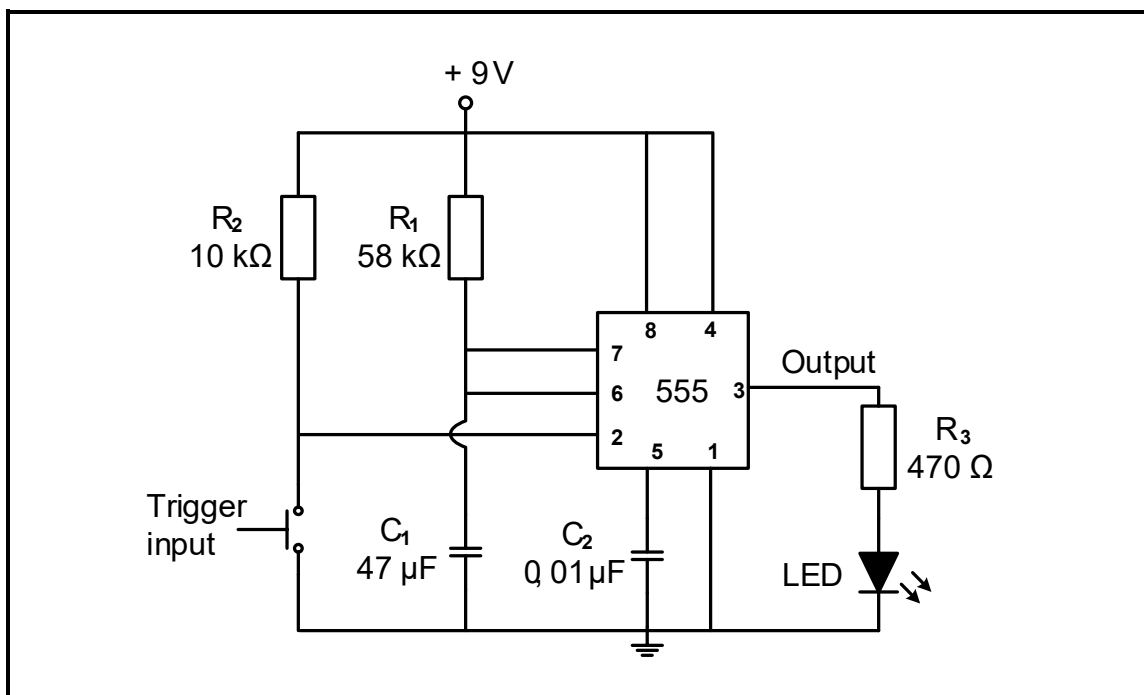
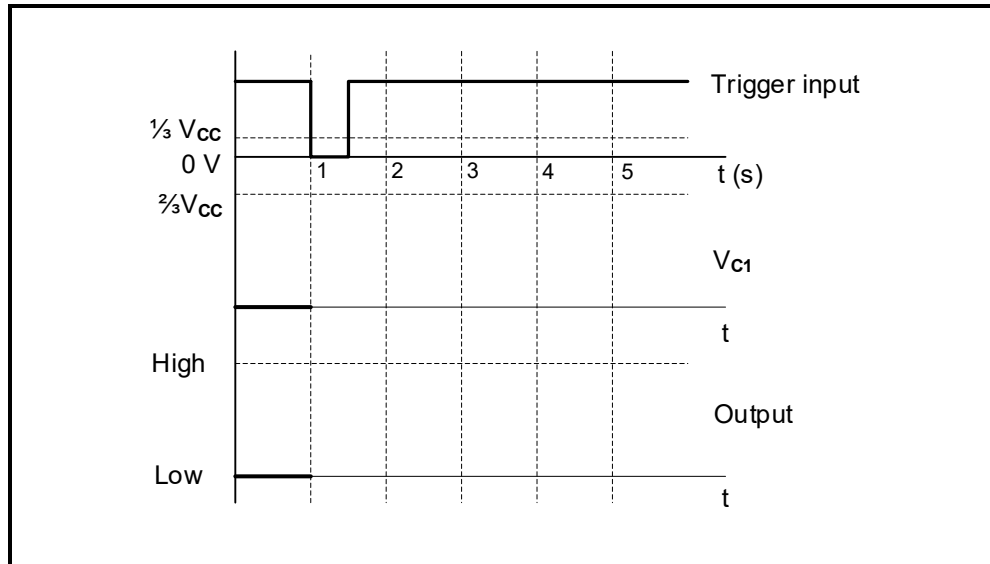

**FIGURE 5.3: MONOSTABLE MULTIVIBRATOR**

5.3.1 Name TWO practical applications of a monostable multivibrator circuit.

(2)

5.3.2 Refer to FIGURE 5.3.2 below and draw on the ANSWER SHEET for QUESTION 5.3.2, the waveforms for the voltage across capacitor  $C_1$  ( $V_{C1}$ ) and the correlating output when the circuit in FIGURE 5.3 on the previous page is set to have a time delay of 3 seconds once the trigger input is activated.



**FIGURE 5.3.2**

(5)

5.3.3 Determine the threshold voltage value at which capacitor  $C_1$  will start discharging.

(2)

5.3.4 Refer to FIGURE 5.3.4 below and complete the equivalent 741 op amp monostable multivibrator circuit diagram on the ANSWER SHEET for QUESTION 5.3.4.

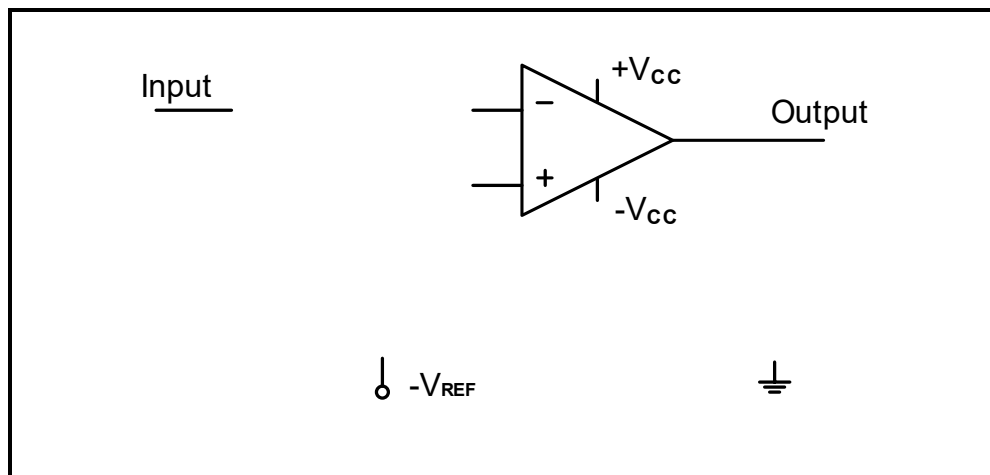

**FIGURE 5.3.4: INCOMPLETE 741 MONOSTABLE MULTIVIBRATOR**

(5)

5.4 Refer to FIGURE 5.4 below and answer the questions that follow.

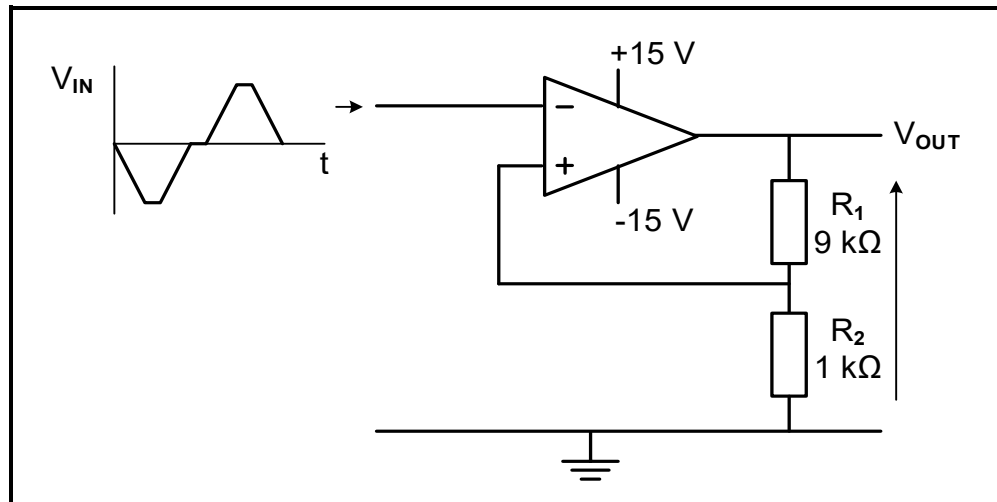

**FIGURE 5.4: INVERTING SCHMITT TRIGGER**

- 5.4.1 Name the type of feedback used in this circuit. (1)
- 5.4.2 Explain the term *trigger voltage* with reference to the circuit. (2)
- 5.4.3 Determine the approximate values of the *upper* AND *lower* trigger voltages. (2)
- 5.4.4 Draw the output signal for the circuit in FIGURE 5.4 above on the ANSWER SHEET for QUESTION 5.4.4. (4)

5.5 FIGURE 5.5 below shows a summing operational amplifier with  $R_F$  set to 100 kΩ. ALL signals on the input are pure sine waves. Answer the questions that follow.

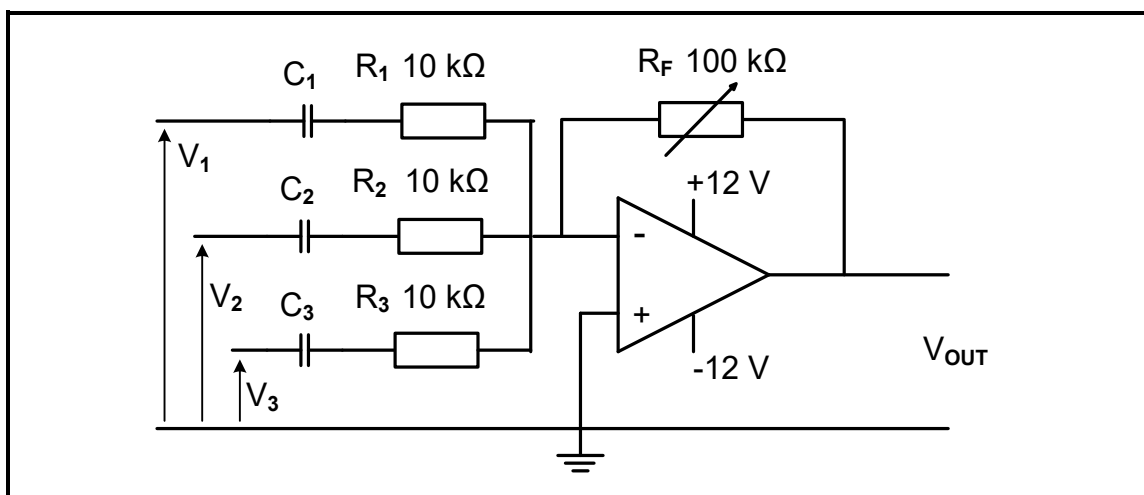

**FIGURE 5.5: SUMMING AMPLIFIER**

Given:

- $R_1, R_2, R_3 = 10 \text{ k}\Omega$
- $R_F = 100 \text{ k}\Omega$  (variable)
- $V_1, V_2, V_3 = 0,4 \text{ V}$

- 5.5.1 Explain ONE characteristic that makes this type of circuit suitable for use in audio mixing applications. (2)
- 5.5.2 Calculate the output voltage of the circuit if  $R_F$  is set to 100 k $\Omega$ . (3)
- 5.5.3 Calculate the voltage gain of the amplifier. (3)
- 5.5.4 When  $V_2$  is increased to 0,6 V, the calculated output changes to -14 V. Answer the following questions:
- (a) Describe how the shape of the output signal will change when  $V_2$  is increased to 0,6 V. (2)
- (b) Explain why the output signal was affected in QUESTION 5.5.4(a). (1)
- (c) State how the change in signal shape can be fixed without decreasing the value of any of the inputs. (1)

5.6 Refer to FIGURE 5.6 and answer the questions that follow.

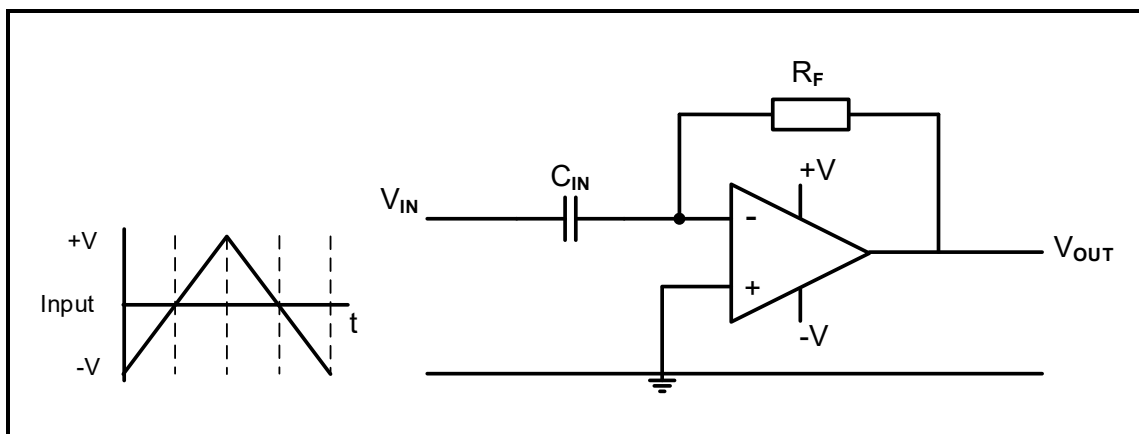

**FIGURE 5.6: OP-AMP DIFFERENTIATOR**

- 5.6.1 Determine the voltage at the inverting input terminal of the op amp before the input signal is fed into the circuit. Motivate your answer. (2)
- 5.6.2 Explain the relationship between the *input* and *output voltage* of the circuit in FIGURE 5.6 above. (2)

**[50]**

**QUESTION 6: AMPLIFIERS**

- 6.1 Briefly describe the purpose of an amplifier. (2)
- 6.2 Refer to FIGURE 6.2 below and answer the questions that follow.

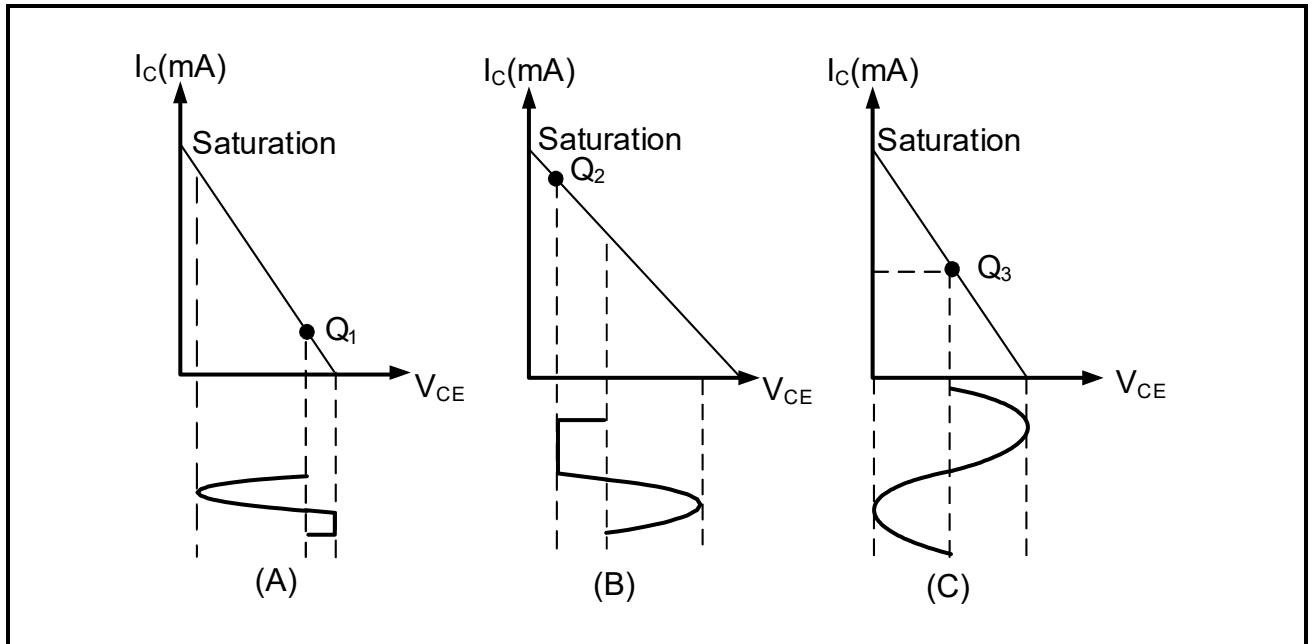

**FIGURE 6.2: DC LOAD LINES**

- 6.2.1 State the class of amplification represented by FIGURE 6.2(A) above. (1)
- 6.2.2 Explain why the positive half-cycle is distorted in FIGURE 6.2(B) above. (2)
- 6.2.3 Identify the class of amplification at FIGURE 6.2(C) above. Motivate your answer. (3)

6.3 Refer to FIGURE 6.3 below and answer the questions that follow.

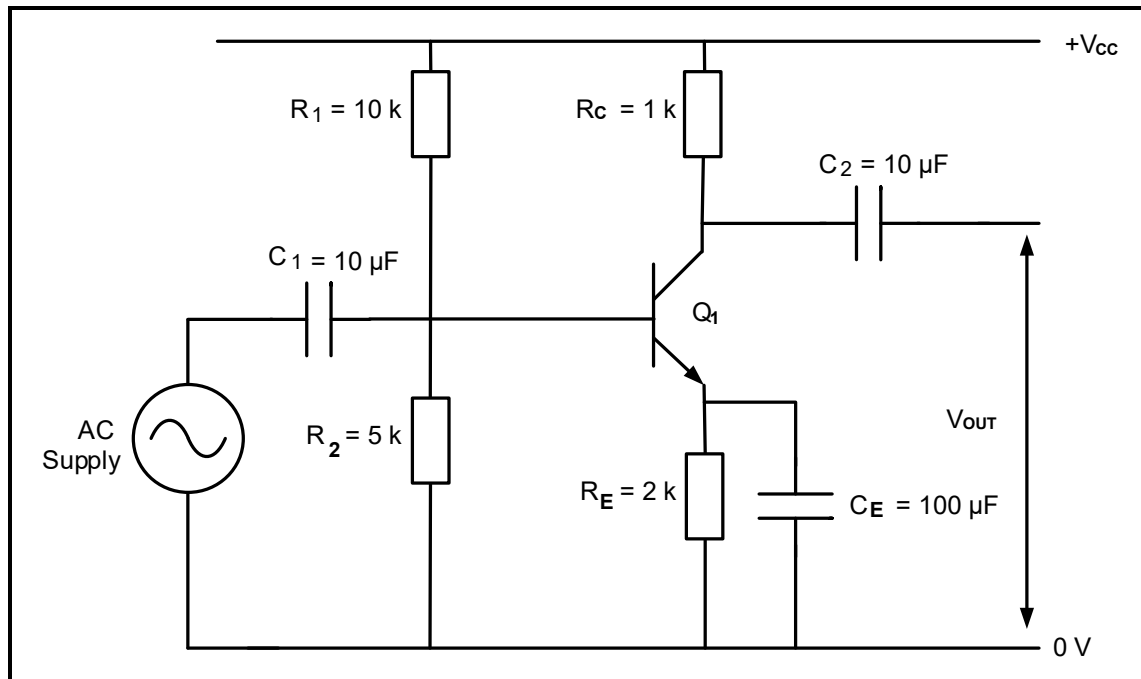

**FIGURE 6.3: RESISTOR CAPACITOR-COUPLED AMPLIFIER**

- 6.3.1 State how the reactances of the coupling ( $C_1$  and  $C_2$ ) and decoupling capacitor ( $C_E$ ) will be affected at lower frequencies in FIGURE 6.3 above. (1)
- 6.3.2 Explain the function of  $R_1$  and  $R_2$  in FIGURE 6.3 above. (2)
- 6.3.3 Calculate the circuit's gain in decibels if the circuit produces 3 W of sound when the input power is 6 W. (3)
- 6.3.4 Explain why  $R_1$  and  $C_1$  are referred to as a low-frequency filter. (3)
- 6.3.5 Draw the output waveform of the emitter amplifier on the ANSWER SHEET for QUESTION 6.3.5. (3)

6.4 FIGURE 6.4 below shows an amplifier circuit diagram. Answer the questions that follow.

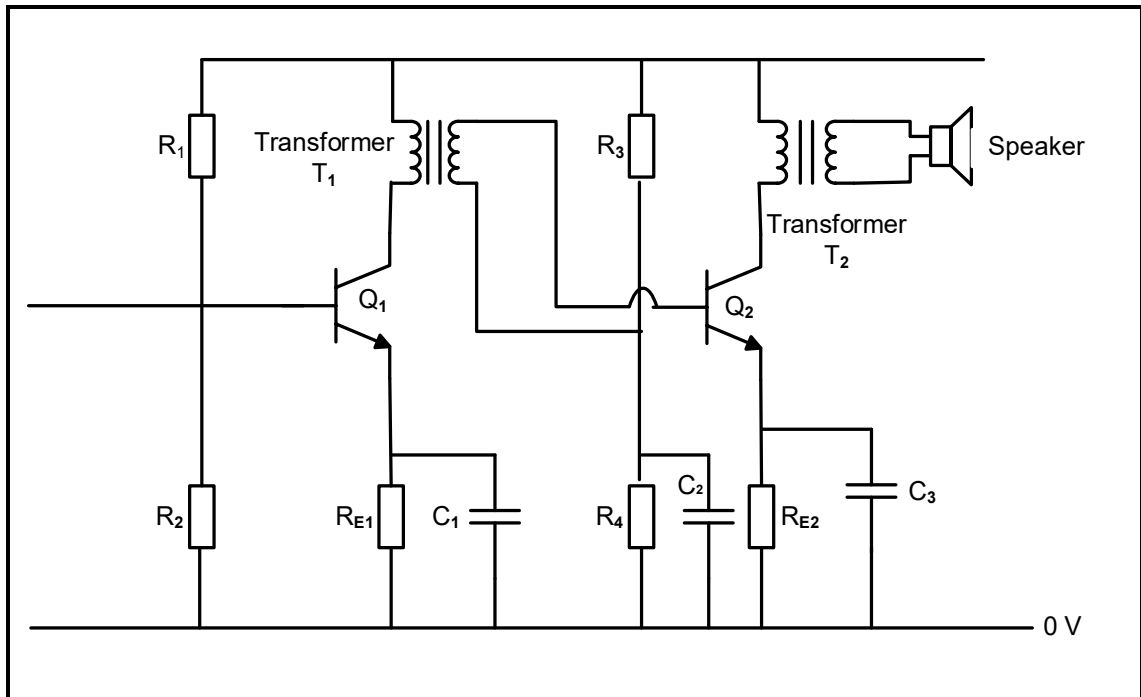

**FIGURE 6.4: TWO-STAGE TRANSFORMER-COUPLED AMPLIFIER**

- 6.4.1 State the function of transistor Q<sub>1</sub>. (1)
- 6.4.2 State TWO applications of the circuit in FIGURE 6.4 above. (2)
- 6.4.3 Describe the advantage of using a transformer-coupled amplifier over a resistance-coupled amplifier. (2)

6.5 Refer to FIGURE 6.5 below and answer the questions that follow.

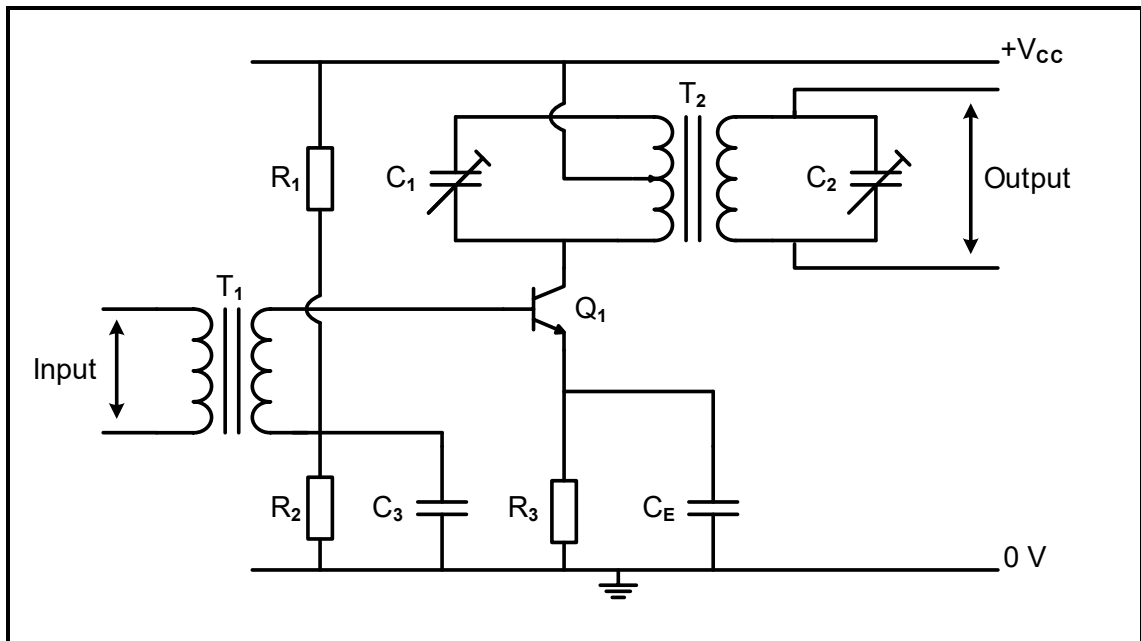

**FIGURE 6.5: RADIO-FREQUENCY (RF) AMPLIFIER**

- 6.5.1 Explain how the circuit in FIGURE 6.5 above is made more frequency selective. (1)
- 6.5.2 Describe the primary function of the impedance matching network in an RF amplifier. (2)
- 6.5.3 Describe how the circuit in FIGURE 6.5 above amplifies the input signals. (3)

6.6 FIGURE 6.6 below shows the circuit diagram of a Hartley oscillator. Answer the questions that follow.

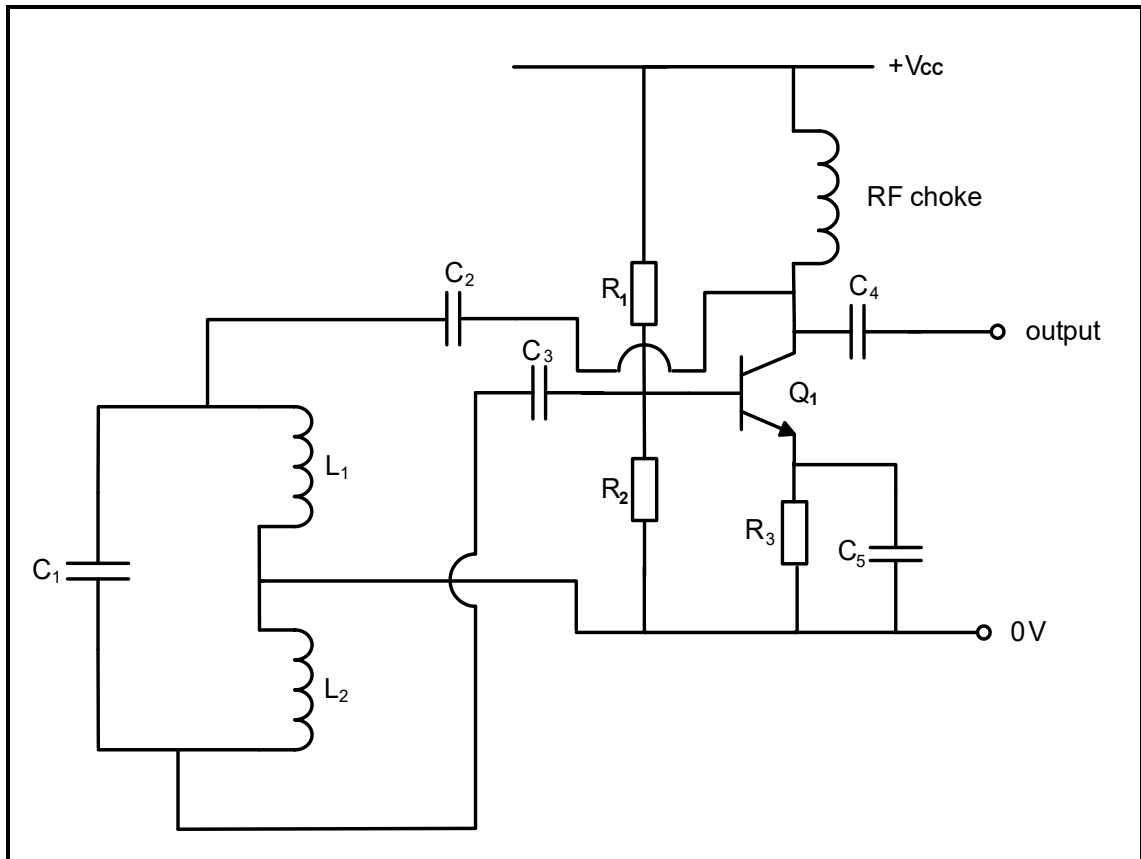

**FIGURE 6.6: HARTLEY OSCILLATOR**

- 6.6.1 Name the type of feedback the Hartley oscillator requires to oscillate. (1)
- 6.6.2 State the primary function of the tank circuit in the Hartley oscillator. (1)
- 6.6.3 Explain how varying the value of capacitor  $C_1$  in the tuned circuit affects the frequency of operation. (2)

6.7 Refer to FIGURE 6.7 below and answer the questions that follow.

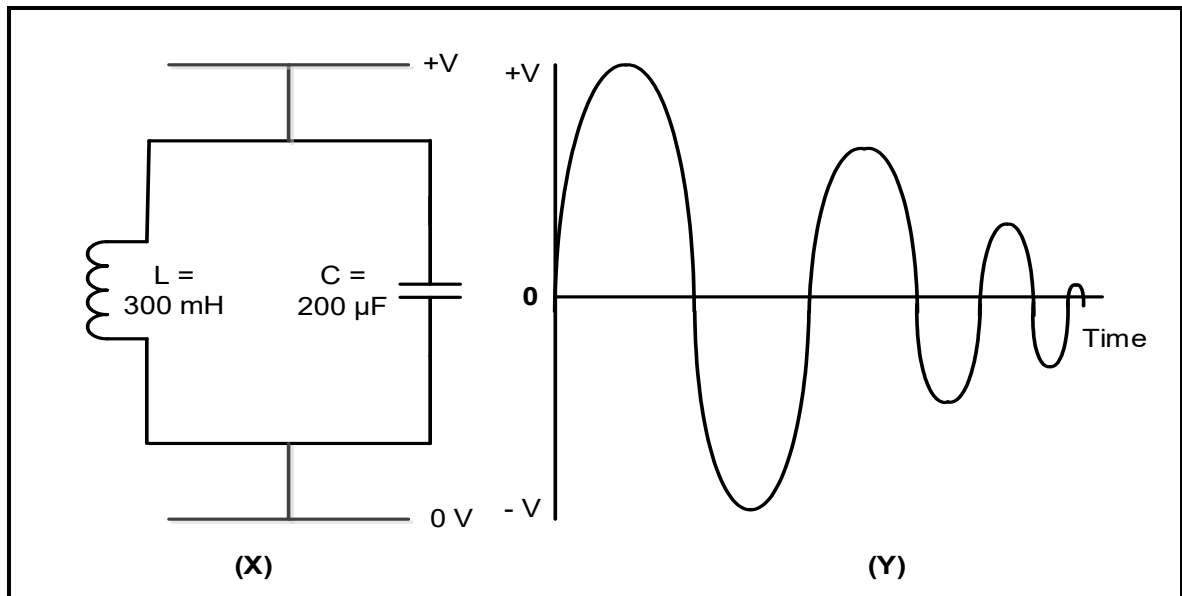

**FIGURE 6.7: TANK CIRCUIT DIAGRAM**

- 6.7.1 Identify the waveform in FIGURE 6.7(Y) above. (1)
- 6.7.2 State how a reduction of the amplitude of the sinusoidal wave in FIGURE 6.7(Y) above can be prevented. (1)
- 6.7.3 Explain the following terms with reference to FIGURE 6.7 above:
- (a) Electrostatic charge of the capacitor (1)
  - (b) Electromagnetic charge of the inductor (1)

6.8 Refer to FIGURE 6.8 below and answer the questions that follow.

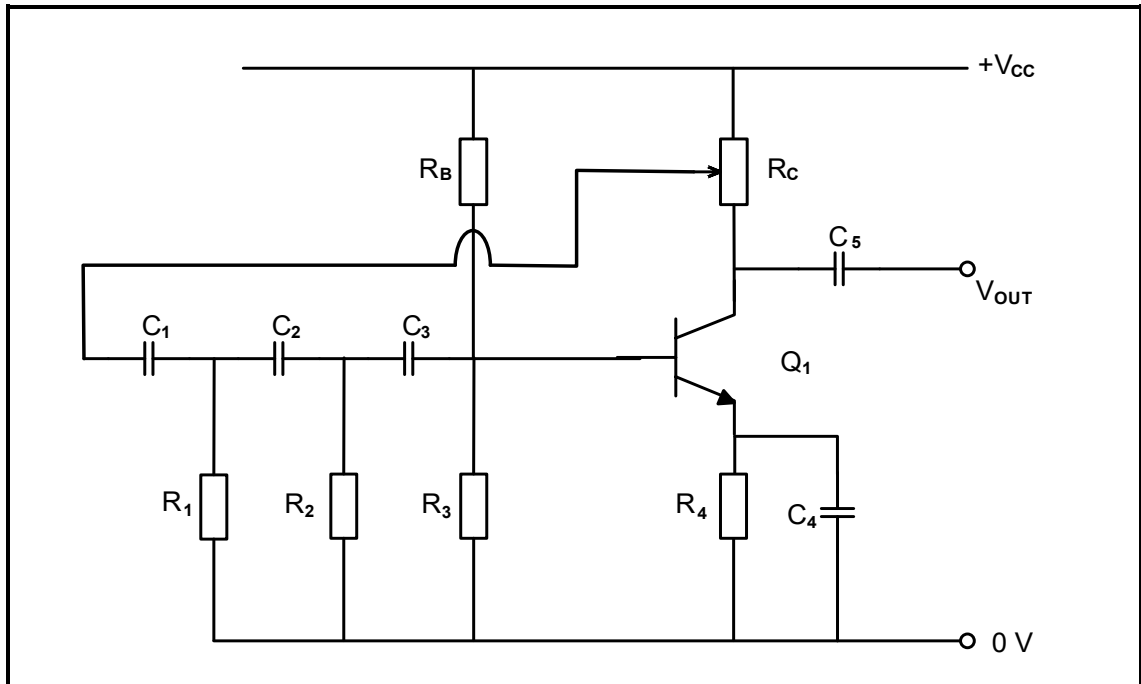

**FIGURE 6.8: RC PHASE-SHIFT OSCILLATOR**

- 6.8.1 Explain the purpose of variable resistor  $R_c$ . (2)
- 6.8.2 State the function of  $R_4$  and  $C_4$ . (2)

6.9 Differentiate between *oscillators* and *amplifiers* with reference to the feedback used. (2)

**[45]**

**TOTAL: 200**

<b>FORMULA SHEET</b>	
<p><b>RLC CIRCUITS</b></p> <p><math>P = V I \cos \theta</math>  <math>X_L = 2\pi fL</math></p> <p><math>X_C = \frac{1}{2\pi fC}</math></p> <p><math>f_r = \frac{1}{2\pi\sqrt{LC}}</math>    <b>OR</b>    <math>f_r = \frac{f_2 + f_1}{2}</math></p> <p><math>BW = \frac{f_r}{Q}</math>    <b>OR</b>    <math>BW = f_2 - f_1</math></p> <p><b>Series</b></p> <p><math>V_R = IR</math>  <math>V_L = IX_L</math>  <math>V_C = IX_C</math></p> <p><math>I_T = \frac{V_T}{Z}</math>    <b>OR</b>    <math>I_T = I_R = I_C = I_L</math></p> <p><math>Z = \sqrt{R^2 + (X_L - X_C)^2}</math></p> <p><math>V_T = \sqrt{V_R^2 + (V_L - V_C)^2}</math>    <b>OR</b>    <math>V_T = IZ</math></p> <p><math>\cos \theta = \frac{R}{Z}</math>    <b>OR</b>    <math>\cos \theta = \frac{V_R}{V_T}</math>    <b>OR</b>    <math>\tan \theta = \frac{V_L - V_C}{V_R}</math></p> <p><math>Q = \frac{X_L}{R} = \frac{X_C}{R} = \frac{V_L}{V_T} = \frac{V_C}{V_T} = \frac{1}{R} \sqrt{\frac{L}{C}}</math></p> <p><b>Parallel</b></p> <p><math>V_T = V_R = V_L = V_C</math></p> <p><math>I_R = \frac{V_T}{R}</math></p> <p><math>I_C = \frac{V_T}{X_C}</math></p>	<p><b>SEMICONDUCTOR DEVICES</b></p> <p>Gain <math>A_V = \frac{V_{OUT}}{V_{IN}} = -\frac{R_F}{R_{IN}}</math>    <b>OR</b>    <math>A_V = 1 + \frac{R_F}{R_{IN}}</math></p> <p><math>V_{OUT} = V_{IN} \times \left(-\frac{R_F}{R_{IN}}\right)</math></p> <p><math>V_{OUT} = V_{IN} \left(1 + \frac{R_F}{R_{IN}}\right)</math></p> <p><b>SWITCHING CIRCUITS</b></p> <p><math>V_{OUT} = -\left(V_1 \frac{R_F}{R_1} + V_2 \frac{R_F}{R_2} + \dots + V_N \frac{R_F}{R_N}\right)</math></p> <p>Gain <math>A_V = \frac{V_{OUT}}{V_{IN}} = \frac{V_{OUT}}{(V_1 + V_2 + \dots + V_N)}</math></p> <p><math>V_{OUT} = -(V_1 + V_2 + \dots + V_N)</math></p> <p><math>V_{FB} = V_{SAT} \times \frac{R_2}{R_1 + R_2}</math></p> <p><math>V_{TRIG} = V_{OUT} \times \frac{R_2}{R_1 + R_2}</math></p> <p><b>AMPLIFIERS</b></p> <p><math>I_C = \frac{V_C}{R_C}</math>    <math>V_{CC} = V_{CE} + I_C R_C</math></p> <p><math>V_B = V_{BE} + V_{RE}</math></p> <p><math>A_V = \frac{V_{OUT}}{V_{IN}}</math></p> <p><math>A_I = \frac{I_{OUT}}{I_{IN}}</math></p> <p><math>A_P = \frac{P_{OUT}}{P_{IN}}</math>    <b>OR</b>    <math>A_P = A_V \times A_I</math></p> <p><math>\beta_T = \beta_1 \times \beta_2</math>    <b>OR</b>    <math>A_{VT} = A_{V1} \times A_{V2} \times A_{V3} \times \dots \times A_{Vn}</math></p> <p><math>P_{IN} = I^2 \times Z_{IN}</math>    <b>AND</b>    <math>P_{OUT} = I^2 \times Z_{OUT}</math></p> <p><math>V_1 = \frac{R_1}{R_1 + R_2} \times V_{CC}</math>    <math>V_2 = \frac{R_2}{R_1 + R_2} \times V_{CC}</math></p>

$I_L = \frac{V_T}{X_L}$ $I_T = \sqrt{I_R^2 + (I_C - I_L)^2}$ $Z = \frac{V_T}{I_T}$ $\cos \theta = \frac{I_R}{I_T}$ $Q = \frac{R}{X_L} = \frac{R}{X_C}$	<p><b>Oscillation frequency</b></p> $f_o = \frac{1}{2 \times \pi \sqrt{LC_T}} \quad \text{OR} \quad f_o = \frac{1}{2 \times \pi \sqrt{6RC}}$ $f_o = \frac{1}{2 \times \pi \sqrt{L_T C}}$ <p><b>GAIN IN DECIBELS</b></p> $A_I = 20 \log_{10} \frac{I_{OUT}}{I_{IN}}$ $A_V = 20 \log_{10} \frac{V_{OUT}}{V_{IN}} \quad \text{OR} \quad A_V = 20 \log_{10} A_{VT}$ $A_P = 10 \log_{10} \frac{P_{OUT}}{P_{IN}} \quad \text{OR} \quad A_P = 10 \log_{10} \frac{P_2}{P_1}$
--	--





**CENTRE NUMBER:**

**EXAMINATION NUMBER:**

**ANSWER SHEET**

**QUESTION 5: SWITCHING CIRCUITS**

5.2.3

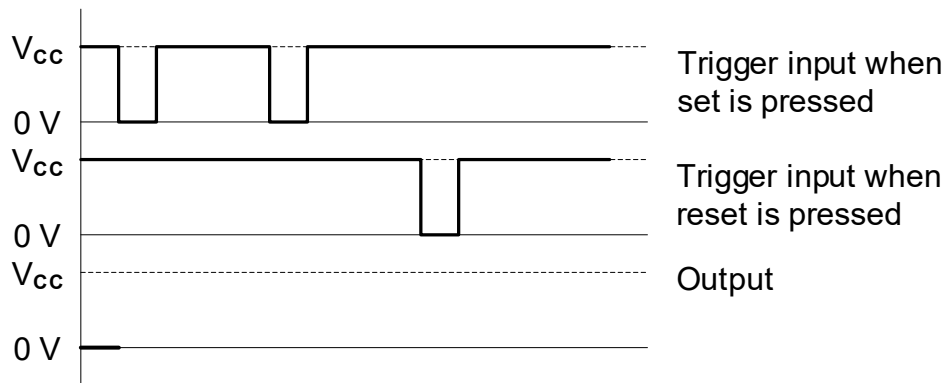

Transfer mark to answer book

MOD

**FIGURE 5.2.3**

(4)

5.3.2

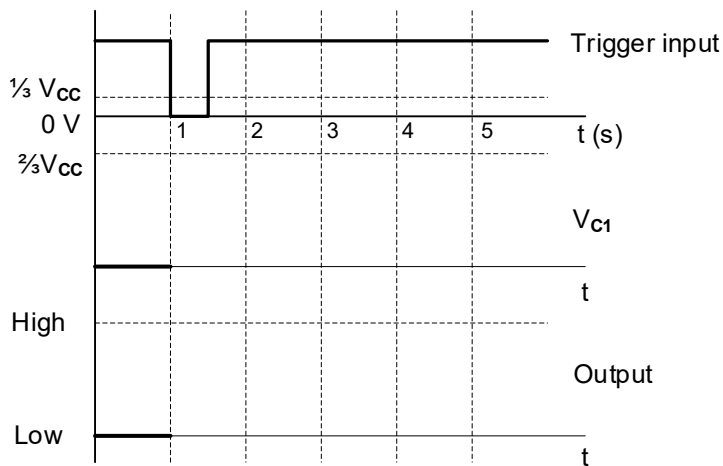

Transfer mark to answer book

MOD

**FIGURE 5.3.2**

(5)





**CENTRE NUMBER:**

**EXAMINATION NUMBER:**

**ANSWER SHEET**

**QUESTION 6: AMPLIFIERS**

6.3.5

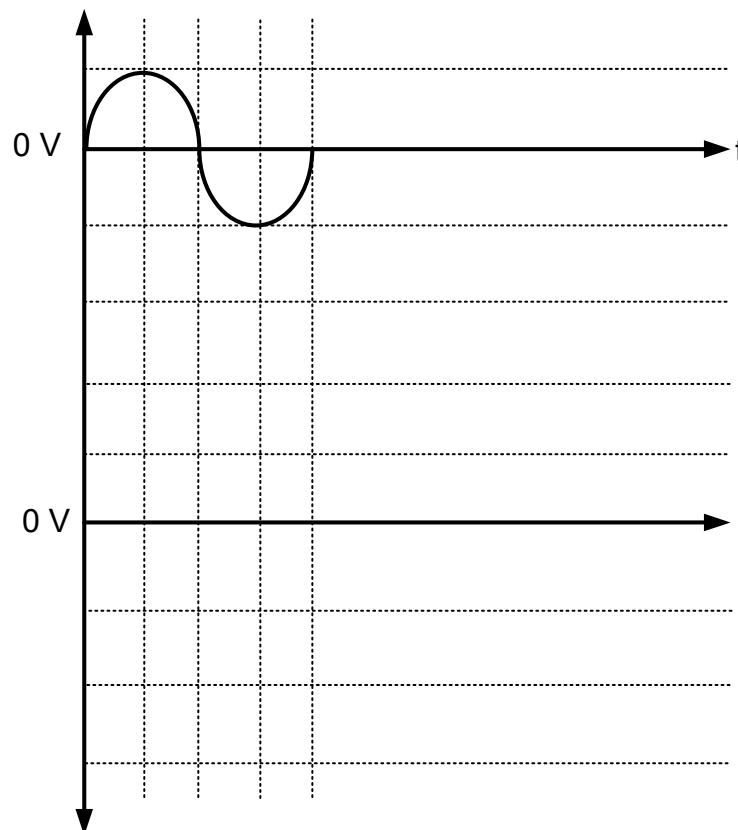

Transfer mark to answer book

MOD

**FIGURE 6.3.5**

(3)