



basic education

Department:
Basic Education
REPUBLIC OF SOUTH AFRICA

**NATIONAL
SENIOR CERTIFICATE**

GRADE 12

ELECTRICAL TECHNOLOGY: ELECTRONICS

NOVEMBER 2025

MARKING GUIDELINES

MARKS: 200

These marking guidelines consist of 15 pages.

INSTRUCTIONS TO THE MARKERS

1. All questions with multiple answers imply that any relevant, acceptable answer should be considered.
2. Calculations:
 - 2.1 All calculations must show the formulae.
 - 2.2 Substitution of values must be done correctly.
 - 2.3 All answers **MUST** contain the correct unit to be considered.
 - 2.4 Alternative methods must be considered, provided that the correct answer is obtained.
 - 2.5 Where an incorrect answer could be carried over to the next step, the first answer will be deemed incorrect. However, should the incorrect answer be carried over correctly, the marker has to re-calculate the values, using the incorrect answer from the first calculation. If correctly used, the candidate should receive the full marks for subsequent calculations.
3. These marking guidelines is only a guide with model answers. Alternative interpretations must be considered and marked on merit. However, this principle should be applied consistently throughout the marking session at ALL marking centres.

QUESTION 1: MULTIPLE-CHOICE QUESTIONS

- | | | |
|------|-------|-------------|
| 1.1 | B ✓ | (1) |
| 1.2 | B ✓ | (1) |
| 1.3 | C ✓ | (1) |
| 1.4 | C ✓ | (1) |
| 1.5 | A ✓ | (1) |
| 1.6 | D ✓ | (1) |
| 1.7 | C ✓ | (1) |
| 1.8 | C/D ✓ | (1) |
| 1.9 | B ✓ | (1) |
| 1.10 | B ✓ | (1) |
| 1.11 | C ✓ | (1) |
| 1.12 | D ✓ | (1) |
| 1.13 | D ✓ | (1) |
| 1.14 | B ✓ | (1) |
| 1.15 | C ✓ | (1) |
| | | [15] |

QUESTION 2: OCCUPATIONAL HEALTH AND SAFETY

- 2.1 Any article or combination of articles assembled, arranged or connected which is used for converting any form of energy ✓ to performing work. ✓

OR

Any article or combination of articles which is used or intended to be used, whether incidental there to or not, for developing, receiving, storing, containing, confining, transforming, transmitting, transferring or controlling any form of energy. (2)

- 2.2 Do not touch the person with bare hands. ✓
Use a non-conductive material to free the person from the live connection. ✓
Switch off the supply (2)

- 2.3 The use/misuse of power tools ✓ without adhering to safety protocols.
The etching of PC boards ✓ without following safety procedures.
Working on a live system without following safety protocol. (2)

- 2.4 A *critical incident* is an event that causes grave or severe physical injury to a person that requires external emergency services. ✓
An *accident* is an event that may cause injury or damage to property (severe or not severe). ✓ (2)

- 2.5 It is an unsafe act, because it creates an unsafe condition ✓ (no guard on the machine) that is conducted by a person in a manner that may threaten the safety ✓ of people in the workshop. (2)

[10]

QUESTION 3: RLC CIRCUITS

3.1 3.1.1 Resonant frequency ✓ (1)

3.1.2 Quality factor/Q factor ✓ (1)

3.2 3.2.1 $V_T = \sqrt{V_R^2 + (V_L - V_C)^2}$ ✓

$$= \sqrt{202,16^2 + (226,82 - 140,18)^2}$$
 ✓
$$= 219,94 \text{ V}$$
 ✓ (3)

3.2.2 $I_T = \frac{V_T}{Z}$ ✓

$$Z = \frac{V_T}{I_T}$$
 ✓
$$= \frac{219,94}{3,61}$$
 ✓
$$= 60,93 \Omega$$
 ✓ (3)

OR

Calculate $R = 56 \Omega$ and $X_c = 31,83 \Omega$, then $Z = 64,01 \Omega$

3.2.3 $\cos\theta = \frac{V_R}{V_T}$ ✓

If R is calculated:
 $\cos\theta = \frac{R}{Z}$

$$\theta = \cos^{-1}\left(\frac{V_R}{V_T}\right)$$
 ✓

OR $\theta = \cos^{-1}\left(\frac{56}{60,93}\right)$

$$= \cos^{-1}\left(\frac{202,16}{219,94}\right)$$
 ✓
$$= 23,20^\circ$$
 ✓ (3)

NOTE: $\tan\theta = \frac{V_L - V_C}{V_R}$ may also be used.

3.2.4 $X_C = \frac{1}{2\pi f C}$ ✓

At resonance $X_L = X_C$, therefore

$$C = \frac{1}{2\pi f X_C}$$
 ✓
$$= \frac{1}{2\pi \times 50 \times 62,83}$$
 ✓
$$= 50,66 \mu\text{F}$$
 ✓ (3)

3.3

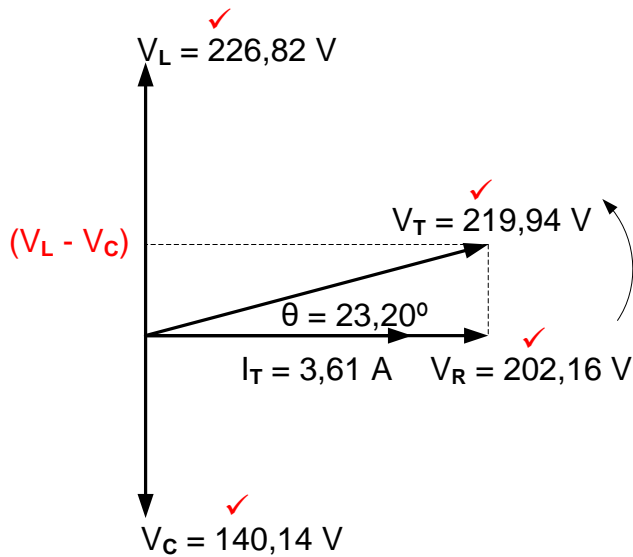

NOTE:

V_L and V_C are the TWO primary labels thereafter any TWO correct labels. If V_L , V_C , V_R , V_T , θ and $(V_L - V_C)$ are written without values, marks will be awarded given there is a distinct difference between the length of the phasors.

3.4 3.4.1
$$I_T = \sqrt{I_R^2 + (I_L - I_C)^2}$$

$$= \sqrt{0,5^2 + (0,9 - 0,2)^2}$$

$$= 0,86 \text{ A}$$
 (3)

3.4.2
$$X_C = \frac{V_T}{I_C}$$

$$= \frac{50}{0,2}$$

$$= 250 \Omega$$
 (3)

3.5 The circuit is more inductive. ✓ The inductive current I_L is greater than the capacitive current I_C . ✓ (2)

3.6 When the frequency increases, X_C decreases ✓ and X_L increases ✓ until they are both equal ✓ and the circuit will resonate.
 When the frequency increases, I_C increases and I_L decreases until they are both equal and the circuit will resonate. (3)

3.7 3.7.1 Parallel RLC circuit. ✓ Impedance is maximum ✓ during resonance in a parallel RLC circuit. (2)

3.7.2 $BW = \frac{f_r}{Q}$ ✓
 $\therefore BW = f_2 - f_1$ ✓
 $(9200 - 5400) = \frac{7300}{Q}$ ✓
 $Q = \frac{7300}{(9200 - 5400)}$ ✓
 $= 1,92$ ✓

(4)
[35]

QUESTION 4: SEMICONDUCTOR DEVICES

- 4.1 4.1.1 JFET. ✓ (1)
- 4.1.2 A = Depletion regions. ✓
B = Source. ✓ (2)
- 4.1.3 To cause a reverse biased PN junction. ✓ (1)
- 4.1.4 The depletion regions narrows, ✓ thereby widening the conduction channel allowing large drain current to flow. ✓ (2)

4.2

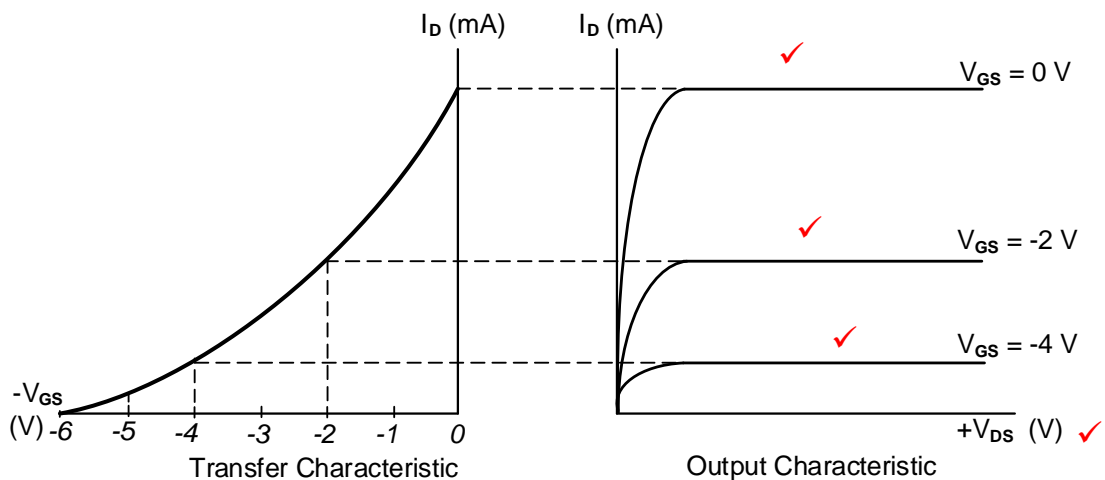

(4)

- 4.3 4.3.1 Depletion mode MOSFET. ✓ (1)
- 4.3.2 A – P-type substrate. ✓
B – Silicon dioxide insulation. ✓
Metal oxide (2)
- 4.3.3 The insulation eliminates any leakage current ✓ between the gate terminal and the drain-source channel. ✓ (2)
- 4.4 The MOSFET has a metal oxide layer which provides insulation between the gate terminal ✓ and the channel.
In the JFET, the gate and the channel are physically connected. ✓ (2)

4.5

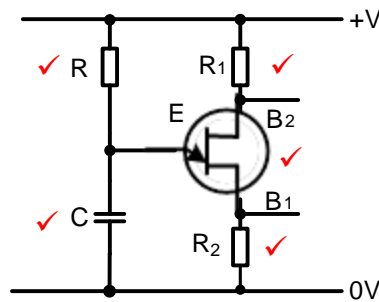

NOTE:

1 mark for each correctly labelled component that is correctly placed and connected.
1 mark for correctly labelling the UJT.

(5)

4.6

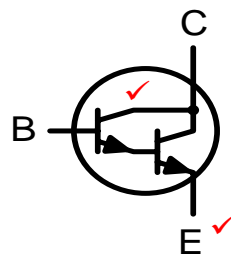

NOTE: The Symbol and the labelling should all be correct for 2 marks to be awarded.

(2)

4.7

Because they can deliver a very high current ✓ that drives the speakers/relay. The Darlington pair provides a high input impedance, low output impedance and high current gain.

(1)

4.8

4.8.1 The purpose of the index dot is to indicate the starting sequence of pin numbering on the 741 IC. ✓

(1)

4.8.2 The sine wave will appear on the output pin in an inverted form ✓ to when it entered the op amp and it will be amplified. ✓

(2)

4.8.3 To allow its output to rise above 0 V ✓ or fall below 0 V. ✓

(2)

4.9

The op amp as a voltage follower/buffer. ✓

(1)

4.10

The intermediate stage compares the differential output from the first stage ✓ and amplifies this difference, ✓ resulting in very high overall voltage gain possessed by an op-amp.

(2)

4.11

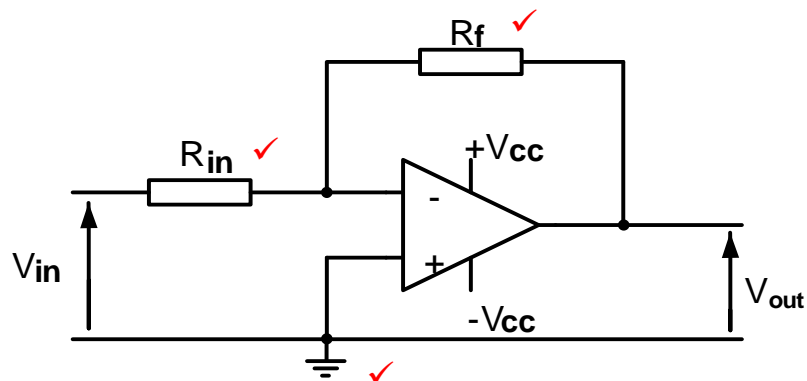

(3)

- 4.12 4.12.1 A- Discharge ✓ pin
B- Threshold ✓ pin (2)
- 4.12.2 The RS flip flop has two stable states ✓ that stores the information it last received ✓ or until new information is received. (2)
- 4.12.3 The reason is to prevent the 555 IC from resetting ✓ because if pin 4 is connected to 0 V ✓ or ground it will reset the 555 IC. (2)
- 4.12.4 Pin 5 must be connected to ground ✓ via a small value capacitor ✓ of 0,01 μF . (2)
- 4.12.5 Astable mode. ✓
Monostable mode
Bistable mode (1)
- [45]**

QUESTION 5: SWITCHING CIRCUITS

- 5.1 5.1.1 Comparator ✓ (1)
- 5.1.2 Reference voltage is a fixed voltage ✓ on one of the inputs of an op amp against which the input on the other terminal of an op amp is being compared. ✓ (2)
- 5.2 5.2.1 R_1 and R_2 act as pull-up resistors ✓ keeping the voltage at pin 2 and 4 high. ✓ (2)
- 5.2.2 Without resistors R_1 and R_2 the input at pin 2 and 4 will be fluctuating ✓ between +V and 0 V. ✓ (2)
- Without R_1 and R_2 , and if you instead directly connect pins 2 & 4 to +V, the pins will be held at +V and the push-buttons will either do nothing (if removed) or create a short when pressed (if still present). This removes the intended set/reset function. (2)

5.2.3

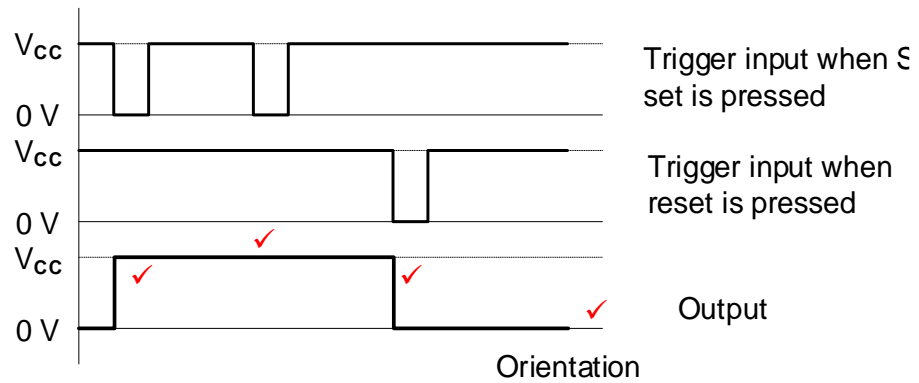

NOTE: 1 mark for the first trigger point
 1 mark for the output not triggering at the second set pulse
 1 mark for the output triggering at the reset pulse
 1 mark for the correct orientation (4)

5.3 5.3.1 Debouncing of switches in digital counters. ✓
 Timing circuits. ✓ (2)

5.3.2

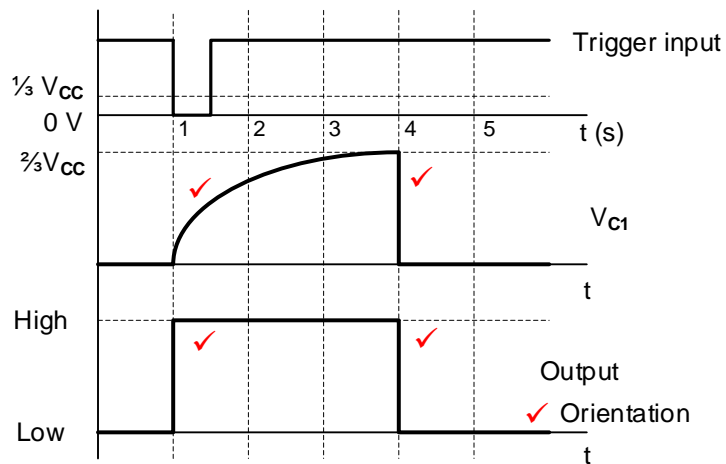

5.3.3 The threshold voltage is $\frac{2}{3}$ of V_{CC} ✓ which equates to 6 V. ✓ (2)
NOTE: If the learner only refers to $\frac{2}{3}$ of V_{CC} , then 1 mark must be awarded.

5.3.4

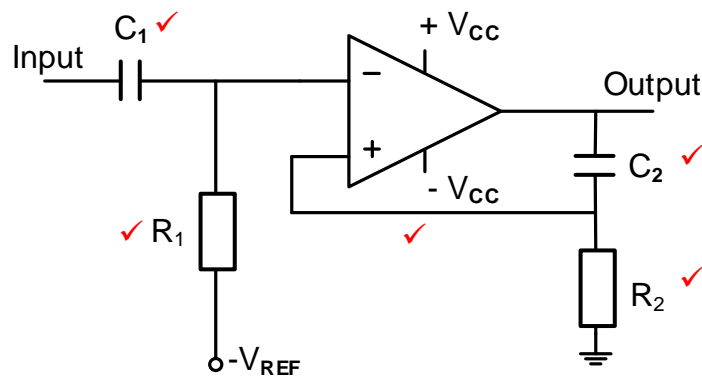

(5)

5.4. 5.4.1 Positive feedback. ✓
Regenerative feedback.

(1)

5.4.2 Trigger voltage refers to the feedback voltage on the non-inverting terminal ✓ created by the voltage dividers R_1 & R_2 ✓ against which the input voltage on the inverting input is compared.

(2)

5.4.3 +1,5 V ✓
-1,5 V ✓

(2)

5.4.4

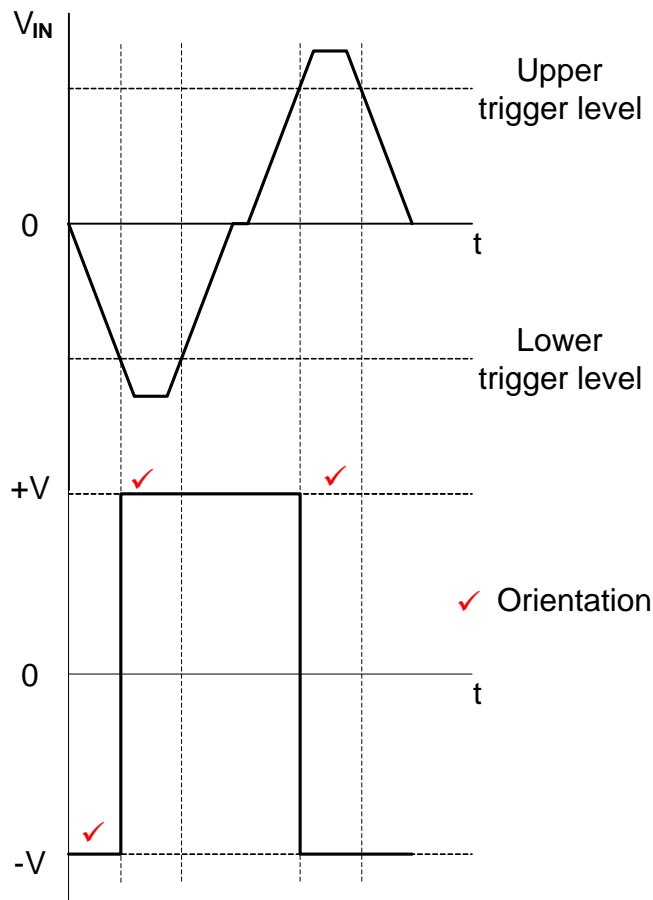

NOTE:

Because initial output state is not given, start at both +V or -V are accepted

(4)

5.5 5.5.1 Various inputs can be received from different microphones ✓ to produce one combined output signal. ✓

(2)

5.5.2

$$V_{OUT} = - \left(V_1 \times \frac{R_F}{R_1} + V_2 \times \frac{R_F}{R_2} + V_3 \times \frac{R_F}{R_3} \right) \quad \checkmark$$

$$= - \left(0,4 \times \frac{100\,000}{10\,000} + 0,4 \times \frac{100\,000}{10\,000} + 0,4 \times \frac{100\,000}{10\,000} \right) \quad \checkmark$$

$$= -12\,V \quad \checkmark$$

(3)

NOTE: The following formula can also be used

$$V_o = \frac{R_f}{R_i} (V_1 + V_2 + V_3)$$

5.5.3

$$A_v = \frac{V_{OUT}}{(V_1 + V_2 + V_3)} \quad \checkmark$$

$$= \frac{-12}{(0,4 + 0,4 + 0,4)} \quad \checkmark$$

$$= -10 \quad \checkmark$$

(3)

- 5.5.4 (a) The output signal will be distorted ✓ with the top and bottom part of the waveform clipped. ✓ (2)
- (b) It is limited by the supply voltage of 12 V. ✓ (1)
- (c) Reduce the value of R_F . ✓
Change the value of the power supply voltages to ± 15 V so that the op amp does not saturate at ± 14 V.
Increasing the value of R_2 to 15 k Ω or above. (1)
- 5.6 5.6.1 0 V, ✓ because the non-inverting input terminal is connected to ground. ✓ (2)
- 5.6.2 The output voltage is directly proportional ✓ to the inverse of the rate of change ✓ of the input voltage. (2)
- [50]**

QUESTION 6: AMPLIFIERS

- 6.1 The purpose of an amplifier is to produce an output which follows the characteristics of the input signal ✓ and is sufficiently large enough to supply the needs of the load ✓ connected to it.
- OR**
- The purpose of an amplifier is to produce the larger output signal from the applied smaller input signal and must be sufficient to drive the output load. (2)
- 6.2 6.2.1 Class AB ✓ (1)
- 6.2.2 The transistor is biased near the saturation region ✓ and any positive half cycle would enter the saturation region and be distorted. ✓ (2)
- 6.2.3 Class A amplification. ✓ The Q - point of class A amplifier lies in the middle of the DC load line ✓ and provide a maximum undistorted output waveform. ✓ (3)
- 6.3 6.3.1 The reactance's of the capacitors will rise. ✓ (1)
- 6.3.2 The function of R_1 and R_2 acts as voltage dividers ✓ and used to bias the transistor ON. ✓ (2)
- 6.3.3
$$A_P = 10 \log_{10} \frac{P_{out}}{P_{in}} \quad \checkmark$$

$$A_P = 10 \log_{10} \frac{3 \text{ W}}{6 \text{ W}} \quad \checkmark$$

$$A_P = -3,01 \text{ dB} \quad \checkmark$$
 (3)
- 6.3.4 The R_C and C_1 network will block DC ✓ and low frequencies ✓ while at the same time allowing high frequency ✓ AC signals to pass. (3)

6.3.5

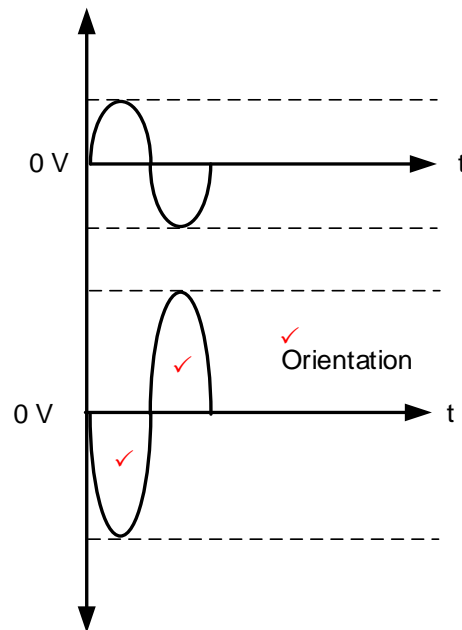

NOTE: 1 mark for each amplified signal = 2
1 mark for orientation = 1

(3)

- 6.4 6.4.1 Q_1 is the first stage transistor used to amplify small input signals. ✓ (1)
- 6.4.2
- Used in impedance matching. ✓
 - Use as driver amplifier or output amplifier. ✓
 - Used to drive low impedance speakers. (2)
- 6.4.3
- Excellent impedance matching can be achieved. ✓
 - Total DC isolation between stages. ✓ (2)
- 6.5 6.5.1 To make the circuit more frequency selective a second capacitor is added to the transformer secondary winding ✓ creating a second LC tuned circuit. (1)
- 6.5.2 The primary function of the impedance matching network is to match the impedance of the RF amplifier ✓ to the impedance of the load (e.g. antenna) ✓ to ensure maximum power transfer. (2)
- 6.5.3 The weak Radio frequency signal is fed into the amplifier through an antenna. ✓ The Radio frequency is amplified by the active devices such as the transistor ✓ which increases the power and the voltage at the output. ✓ (3)

- 6.6 6.6.1 Positive feedback. ✓ (1)
- 6.6.2 The primary function of the tank circuit is to determine the oscillation frequency by resonating at a specific frequency. ✓
To store energy. (1)
- 6.6.3 Decreasing the value of capacitor (C_1) increases the frequency of operation, ✓ while increasing the value of the capacitor (C_1) decreases the frequency of operation. ✓ (2)
- 6.7 6.7.1 Decaying sinusoidal waveform ✓ / damped oscillation waveform. (1)
- 6.7.2 The circuit must be continually energised ✓ with charge cycles as it continually loses energy in each energy exchange (capacitor charging and discharging through the inductor). (1)
- 6.7.3 (a) Electro-static charge is the energy stored in the two plates of the capacitor. ✓ (1)
- (b) Electro-magnetic charge/energy is the energy created when the electro-magnetic field collapses inducing a current in the coil. ✓ (1)
- 6.8 6.8.1 The variable resistor R_c allows for minor adjustments ✓ and circuit tuning ✓ without changing components. (2)
- 6.8.2 R_4 - Provides the path for direct current to pass through ✓ provides bias stability against temperature fluctuations and prevents thermal runaway.
 C_4 - Blocks the DC and allows AC signal to pass through ✓ and keeps the voltage across the resistor constant. (2)
- 6.9 Amplifiers uses negative feedback ✓ and oscillators uses positive feedback. ✓ (2)

[45]**TOTAL: 200**