

*Confidential*



# basic education

Department:  
Basic Education  
**REPUBLIC OF SOUTH AFRICA**

**NATIONAL  
SENIOR CERTIFICATE**

**GRADE 12**

**CIVIL TECHNOLOGY: CIVIL SERVICES**

**NOVEMBER 2025**

**MARKS: 200**

**TIME: 3 hours**

**This question paper consists of 16 pages and 4 answer sheets.**

**REQUIREMENTS:**

1. Drawing instruments
2. A non-programmable calculator
3. ANSWER BOOK

**INSTRUCTIONS AND INFORMATION**

1. This question paper consists of SIX questions.
2. Answer ALL the questions.
3. Read ALL the questions carefully.
4. Answer each question as a whole. Do NOT separate subsections of questions.
5. Number the answers correctly according to the numbering system used in this question paper.
6. Start the answer to EACH question on a NEW page.
7. Do NOT write in the margins of the ANSWER BOOK.
8. You may use sketches to illustrate your answers.
9. Write ALL calculations and answers in the ANSWER BOOK or on the attached ANSWER SHEETS.
10. Use the mark allocation as a guide to the length of your answers.
11. Make drawings and sketches in pencil, fully dimensioned and neatly finished off with descriptive titles and notes to conform to the *SANS/SABS Code of Practice for Building Drawings*.
12. For the purpose of this question paper, the size of a brick should be taken as 220 mm x 110 mm x 75 mm.
13. Use your own discretion where dimensions and/or details have been omitted.
14. Answer QUESTIONS 2, 3.4, 5.4 and 6.8 on the attached ANSWER SHEETS using drawing instruments, where necessary.
15. Write your CENTRE NUMBER and EXAMINATION NUMBER on every ANSWER SHEET and hand them in with your ANSWER BOOK, whether you have used them or not.
16. Drawings in the question paper are NOT to scale due to electronic transfer.
17. Google Images was used as the source of all photographs and pictures.
18. Write neatly and legibly.

**QUESTION 1: OHSA, MATERIALS, TOOLS, EQUIPMENT AND JOINING (GENERIC)..**

Start this question on a NEW page.

- 1.1 Choose the correct word(s) from those given in brackets. Write only the word(s) next to the question numbers (1.1.1 to 1.1.10) in the ANSWER BOOK, e.g. 1.1.11 Plaster.
- 1.1.1 Every plank of a wooden scaffold platform must be at least (28 mm/38 mm) thick. (1)
- 1.1.2 Toe boards should be at least (150 mm/200 mm) high from the level of the scaffold platform. (1)
- 1.1.3 Steel scaffold standards with heavy platform loadings must not exceed (320 kg per m<sup>2</sup>/160 kg per m<sup>2</sup>). (1)
- 1.1.4 The framework of scaffolding must be constructed to have a safety factor of at least (two/three). (1)
- 1.1.5 Trestle scaffolds must not consist of more than (two/four) tiers. (1)
- 1.1.6 When using a builder's hoist (overhead/hand) protection must be provided to protect workers from falling objects. (1)
- 1.1.7 Ladders must not be extended above (two thirds/three quarters) of the extension length. (1)
- 1.1.8 A construction site must be cordoned off to prevent (unauthorised persons/building inspectors) from entering the site. (1)
- 1.1.9 Stairways that will not be a permanent part of the building must have landings of at least (760 x 560 mm/450 x 320 mm) for every 3,7 m vertical rise. (1)
- 1.1.10 The seller shall supply the user of any hazardous chemical substance with sufficient information to enable the user to take necessary measures regarding (safe stocktaking/health and safety). (1)
- 1.2 Which pictorial view below represents a bolt that will resist rotation?

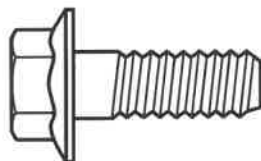
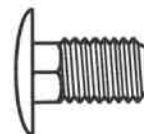
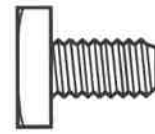
**A****B****C****D**

(1)

- 1.3 Bolts are purchased according to different specifications. Name any TWO of these specifications. (2)
- 1.4 Powder coating is a coating that is applied to metals.
- 1.4.1 Explain the process of powder coating by referring to the material that is used and the method of application. (2)
- 1.4.2 Name ONE advantage of powder coating in terms of applying it to a metal. (1)
- 1.5 What should NOT be used to clean a multidetector? (1)
- 1.6 Name TWO materials that can be detected in a brick wall using the multidetector. (2)
- 1.7 What accessory of the dumpy level will be used to position a telescope on a centre point when horizontal measurements are taken? (1)
- [20]**

**QUESTION 2: GRAPHICS AS MEANS OF COMMUNICATION (GENERIC)**

Start this question on a NEW page.

FIGURE A and FIGURE B on the next page show drawings that appear on a building plan. Analyse the drawings and complete the table on ANSWER SHEET 2.

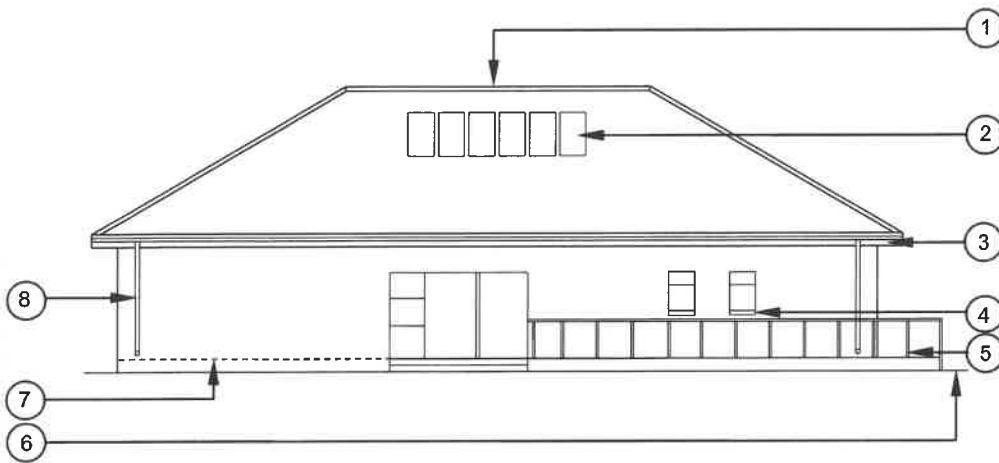

**FIGURE A**

**NOTES:**

Contractors must verify all dimensions and levels on site before commencing work.

Architects to be notified of any discrepancies immediately.

Guard rails on patio to be made of stainless steel.

Aluminium sliding door (2 400 x 2 000 mm)

Aluminium side panel with windows (600 x 2 000 mm)

Roof: Hipped roof

Lintels must be installed above every window.

Architect's signature .....

Client's signature .....

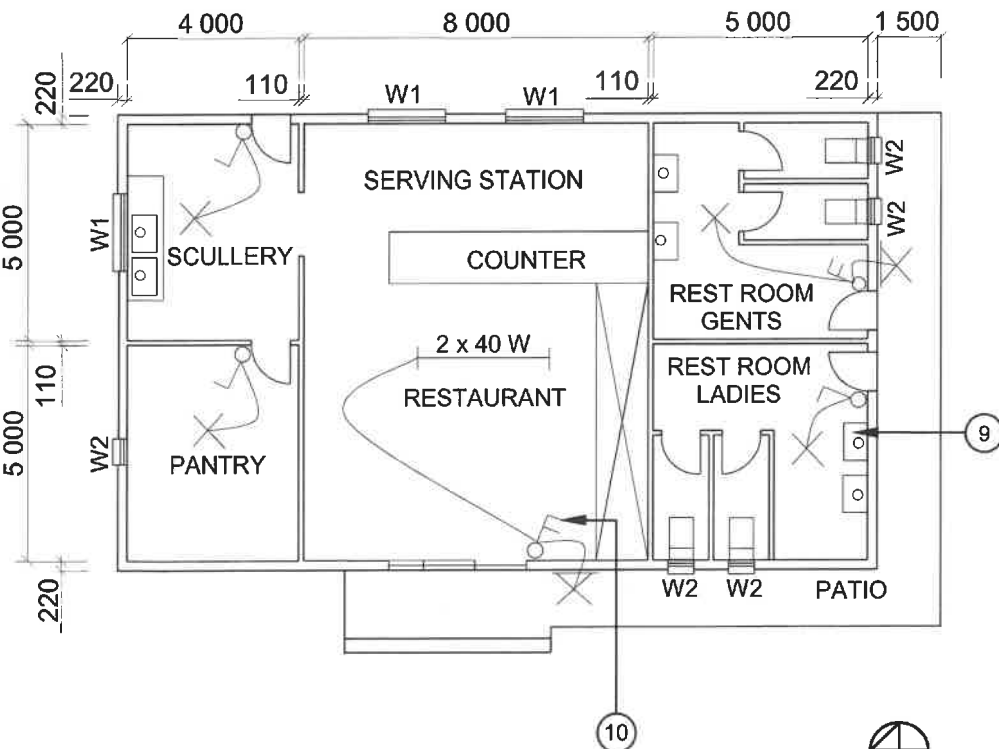

**FIGURE B**

REVISION 1	DATE: 24/05/2025	DRAWING OF ELECTRICAL FITTINGS
------------	---------------------	--------------------------------------

PRINTED BY: BUZZ PRINTERS	DATE OF PRINT: 26/05/2025
------------------------------	------------------------------

DRAWING TITLE:  
ELEVATION AND FLOOR PLAN

PROJECT:  
PROPOSED BUILDING OF MR JD JONES  
ON PLOT 54, PROTEA STREET, CALEDON

PROJECT NO.: GR 866-464	DRAWING NO.: 334P2
----------------------------	-----------------------

DATE: 20/04/2025	DRAWN: N CAR	CHECKED: C BENN
---------------------	-----------------	--------------------

ELEVATION	SCALE 1 : 100
-----------	---------------

FLOOR PLAN	SCALE 1 : 100
------------	---------------

REFERENCE CODE  
QP 5 – 2025

WINDOW SCHEDULE	
<p>1 400 1 800 W1</p>	<p>1 200 600 W2</p>

**[40]**

**QUESTION 3: CONSTRUCTION ASSOCIATED WITH CIVIL SERVICES, OHS&A AND QUANTITIES (SPECIFIC)**

Start this question on a NEW page.

3.1 FIGURE 3.1 below shows a faulty manhole installation.

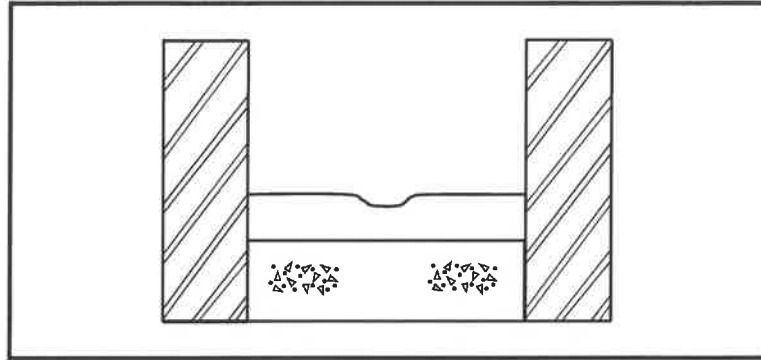
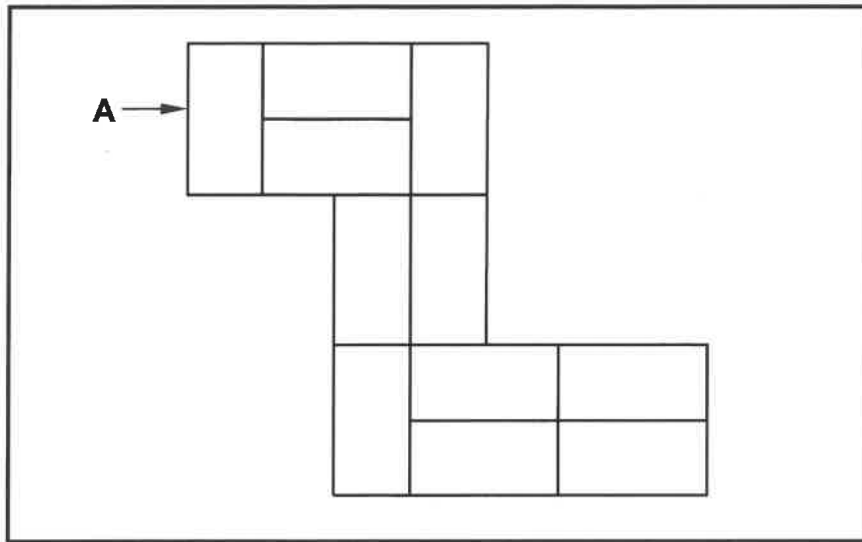

**FIGURE 3.1**

- 3.1.1 Identify any THREE faults in the manhole installation. (3)
- 3.1.2 Any worker working in a manhole where there might be dangerous gases must be assisted by a qualified person in case of an emergency. In which field should this person be qualified? (1)
- 3.1.3 What type of protective equipment is necessary when working in manholes with dangerous gases? (1)
- 3.1.4 Explain why it is NOT advisable to use a dust mask that covers the mouth and nose when working in manholes. (1)
- 3.1.5 Name the recommended brick bond that can be used in the construction of a manhole. (1)
- 3.1.6 Name ONE other type of manhole that is available in the construction industry. (1)
- 3.2 Show, by means of a sketch in your ANSWER BOOK, how the sides of firm ground can be supported during excavations. Label any TWO parts. (7)
- 3.3 The internal measurement of the sides of a cubic water storage tank is 2 650 mm.
- 3.3.1 Calculate the volume of the tank in m<sup>3</sup>. (4)
- 3.3.2 Calculate the volume of the tank in litres. (3)

Show ALL calculations and round off your answer to TWO decimal places.

3.4 FIGURE 3.4 below shows the first course of a double return angle of a one-brick wall in stretcher bond.



**FIGURE 3.4**

Use ANSWER SHEET 3.4 to project and draw the second course of the double return angle of a one-brick wall in stretcher bond.

**NOTE:** Project as seen from the direction of arrow **A**.

(8)  
[30]

**QUESTION 4: COLD- AND HOT-WATER SUPPLY, TOOLS, EQUIPMENT AND MATERIALS (SPECIFIC)**

Start this question on a NEW page.

- 4.1 Choose a description from COLUMN B that matches an item in COLUMN A. Write only the letter (A–L) next to the question numbers (4.1.1 to 4.1.8) in the ANSWER BOOK, e.g. 4.1.9 M.

COLUMN A		COLUMN B	
4.1.1	Non-return valve	A	allows back flow of water in pipes
4.1.2	Expansion control valve	B	controls the pressure of hot water in a geyser
4.1.3	Stopcock	C	a floating device used to regulate water flow
4.1.4	Ball valve in a cistern	D	a device used to shut off the water flow in a pipe system
4.1.5	Element	E	a fitting that allows water to flow in only one direction
4.1.6	Red-water diverter	F	a manually-operated valve used to stop or control water flow in large pipes
4.1.7	Anode	G	heats the water inside a geyser
4.1.8	Mixer tap	H	a device that combines hot and cold water before dispensing
		I	redirects cool water to a rain-water tank before it reaches the tap
		J	a device that increases water pressure in low-pressure systems
		K	sacrifices itself to protect the element inside the geyser
		L	a pipe fitting that allows water to change direction

(8 x 1)

(8)

4.2 FIGURE 4.2 below shows an installation of a hot-water supply system with the corresponding components below the system.

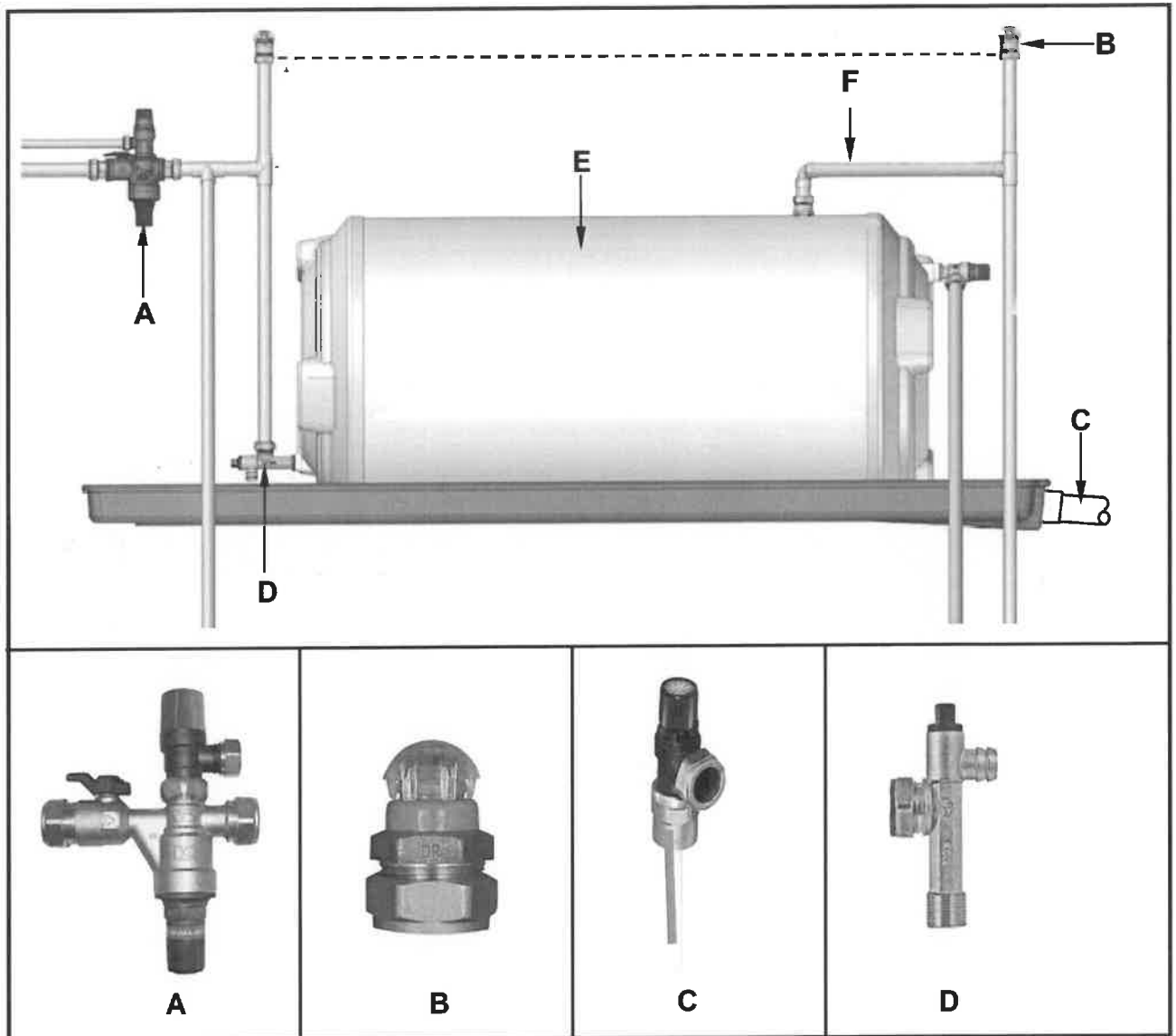

FIGURE 4.2

- 4.2.1 Identify **A** to **D**. (4)
- 4.2.2 Explain why the hot-water outlet is positioned at the top of the geyser, as indicated at pipe **F**. (1)
- 4.2.3 What is the minimum installation height for part **B** from the top of the geyser? (1)
- 4.2.4 Predict what could happen if the part under **E** is not installed. (1)
- 4.2.5 Recommend the diameter of the outlet pipe at **C**. (1)
- 4.2.6 Differentiate between *part A* and *part D* in terms of their use. (2)
- 4.2.7 Draw the symbol used for component **E** in hot-water systems. (2)

- 4.3 Differentiate between a *water-pressure testing pump* and a *centrifugal pump* in terms of their use. (2)
- 4.4 Draw the symbols of the following components that are used in hot-water systems:
- 4.4.1 Non-return valve (2)
- 4.4.2 Shower (movable) (2)
- 4.4.3 Thermostatic controller (2)
- 4.5 Many faults can occur in hot-water systems.
- 4.5.1 Give ONE reason why the water from geysers is sometimes NOT hot enough. (1)
- 4.5.2 Explain how you can prevent a shortage of hot water from a geyser. (2)
- 4.6 FIGURE 4.6 below is a picture of a pipe fitting used for waste-water on the outside of the kitchen.



**FIGURE 4.6**

- 4.6.1 Identify the pipe fitting. (1)
- 4.6.2 Explain the function of the fitting. (1)
- 4.6.3 Explain why the ends of the fitting should be larger than the bend. (1)
- 4.6.4 What should be the diameter of this fitting? (1)
- 4.7 Explain TWO methods that can be used to prevent an electrolytic reaction in a water system. (2)

4.8 FIGURE 4.8 below shows TWO taps.

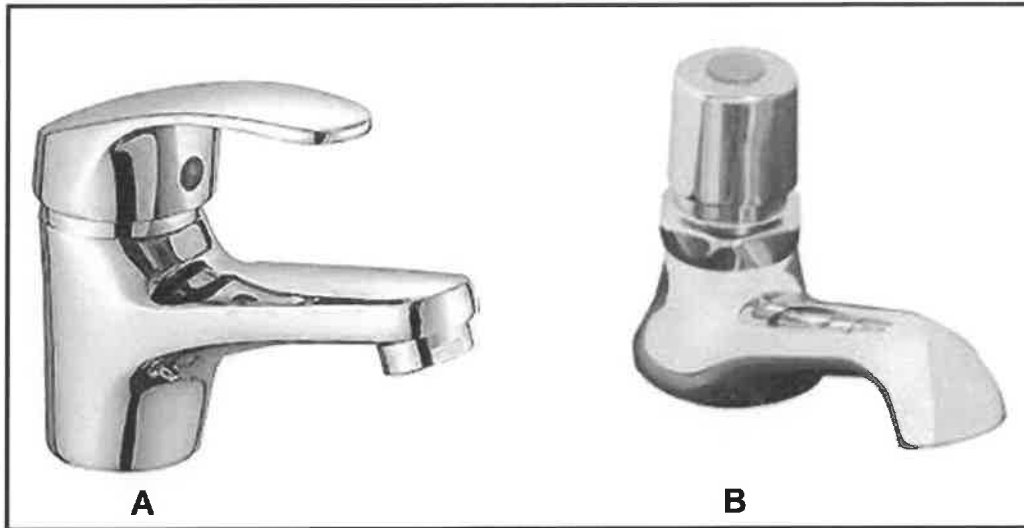

FIGURE 4.8

- 4.8.1 Differentiate between *tap A* and *tap B* in terms of how it saves water. (2)
  - 4.8.2 Name a water-saving tap that can be operated hands-free. (1)
- [40]

**QUESTION 5: GRAPHICS AS MEANS OF COMMUNICATION, ROOF WORK AND STORM WATER (SPECIFIC)**

Start this question on a NEW page.

5.1 Various options are provided as possible answers to the following questions. Choose the answer and write only the letter (A–D) next to the question numbers (5.1.1 to 5.1.5) in the ANSWER BOOK, e.g. 5.1.6 D.

- 5.1.1 The component that is attached to the downpipe, that allows rain-water to flow out, is called the ...
- A gutter.
  - B gully.
  - C holderbat.
  - D shoe. (1)
- 5.1.2 The maximum distance between PVC downpipe clips used to fasten the downpipe to the wall is ...
- A 2 metres.
  - B 3 metres.
  - C 4,5 metres.
  - D 2,5 metres. (1)
- 5.1.3 ... can be used for a flashing at the junction of a wall and the roof.
- A Zinc
  - B PVC
  - C Tin
  - D None of the above-mentioned (1)
- 5.1.4 Soakaways must be installed at least ... from a building.
- A 3 metres
  - B 2 metres
  - C 1 metre
  - D 5 metres (1)
- 5.1.5 Where artificial storm-water channels connect with open natural channels, it must ...
- A correspond with the natural flow of water.
  - B not cause soil erosion.
  - C not damage the surrounding environment.
  - D All the above-mentioned (1)

5.2 FIGURE 5.2 shows gutter components.

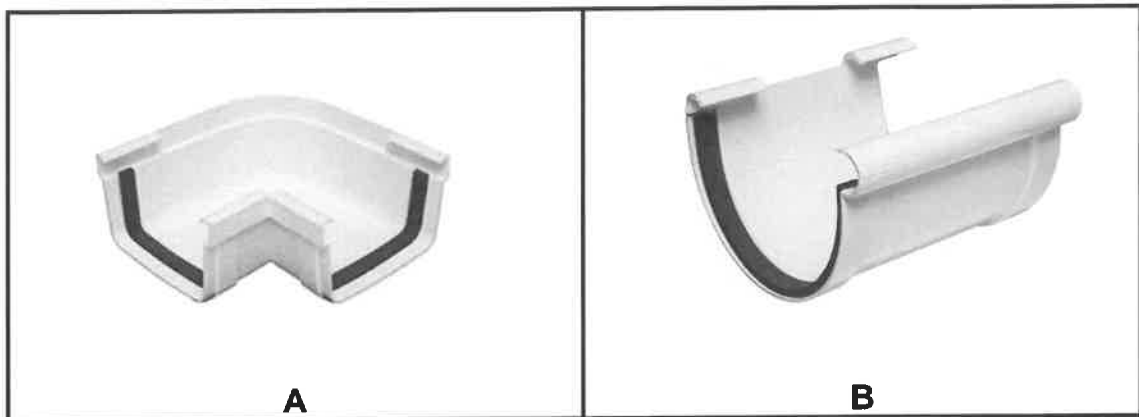

FIGURE 5.2

5.2.1 Identify **A** and **B**. (2)

5.2.2 Describe the locations of **A** and **B** in a rainwater system. (2)

5.3 A new school building has recently been completed. During heavy rainfall, water pooled around the foundation. Explain the possible consequences of the poorly designed storm-water drainage system around the building. (2)

5.4 ANSWER SHEET 5.4 shows the front view and left view of a shoe offset of a cylindrical downpipe.

Use the drawings and information given and only draw the development of pipe **A**.

The pipe has a 3 mm seam on both sides.  
Start the development on the short side indicated by **B**.  
Show ALL construction and projection lines.

(19)  
[30]

**QUESTION 6: SEWERAGE, SANITARY FITTINGS AND JOINING (SPECIFIC)**

Start this question on a NEW page.

- 6.1 Complete the following sentences by using the words provided in the list below. Write only the word(s) next to the question numbers (6.1.1 to 6.1.5) in the ANSWER BOOK, e.g. 6.1.6 Scum.

fermentation; compost; bio-reactor; chlorine; sludge; biomass; hydrochloric acid; septic tank; waste-water; zinc chloride
--

- 6.1.1 During the sewerage treatment process, the ... is chemically treated and separated at a treatment plant. (1)
- 6.1.2 After the separation process, bigger solids are filtered out in the treatment process. The solids are used as ... (1)
- 6.1.3 Effluent in the treatment process is pumped into a ... where bacteria breaks down the harmful matter. (1)
- 6.1.4 Secondary clarifying in the treatment process allows the ... to settle to the floor of the tank. (1)
- 6.1.5 The water in the treatment process is chemically treated with ... to make it safe for drinking. (1)

6.2 FIGURE 6.2 below illustrates a sink installation.

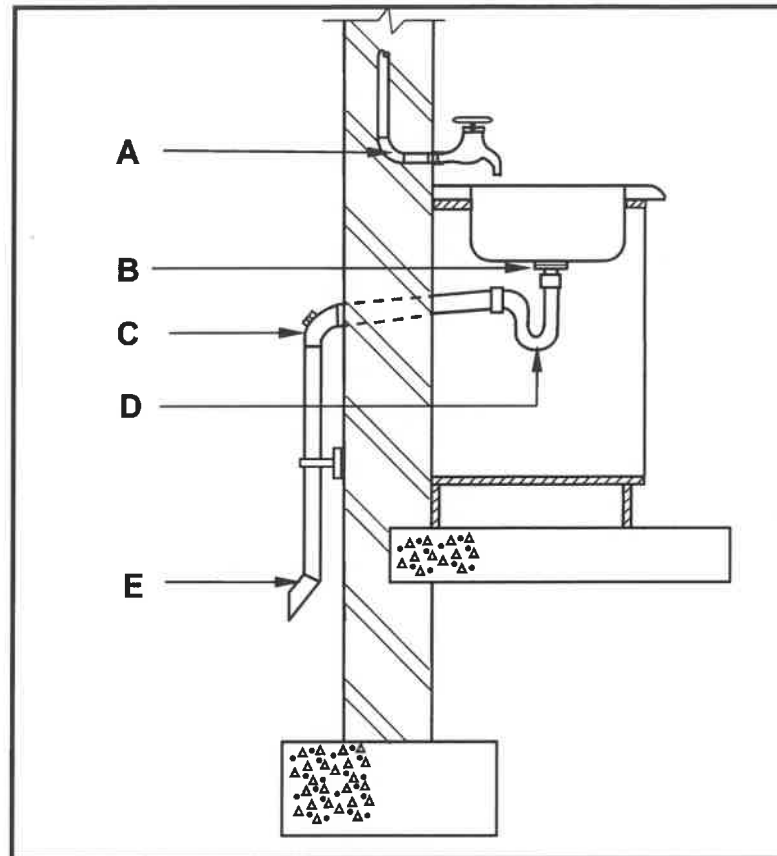

**FIGURE 6.2**

- 6.2.1 Identify **A**. (1)
- 6.2.2 What is the purpose of the rubber washer that is fitted underneath the basin outlet indicated at **B**? (1)
- 6.2.3 Identify **C**. (1)
- 6.2.4 Name the adhesive that will be used to join **C** to the waste pipe. (1)
- 6.2.5 Explain the purpose of the P-trap holding water at **D**. (2)
- 6.2.6 Name the fixture that must be installed below **E**. (1)

6.3 An efficient drainage system must comply with certain requirements.

- 6.3.1 Name the component that must be installed in a drainage system when two or more pipes meet or when there is a change of direction in the sewer pipeline. (1)
- 6.3.2 State the minimum number of ventilation pipes that must be installed in a sewerage system. (1)

- 6.4 Name TWO materials that are used to manufacture drain pipes. (2)
- 6.5 State TWO properties of solder. (2)
- 6.6 Predict what the consequence will be when the head of the soldering iron is too cold or too hot when preparing it for the tinning process. (2)
- 6.7 FIGURE 6.7 shows a drainage system.

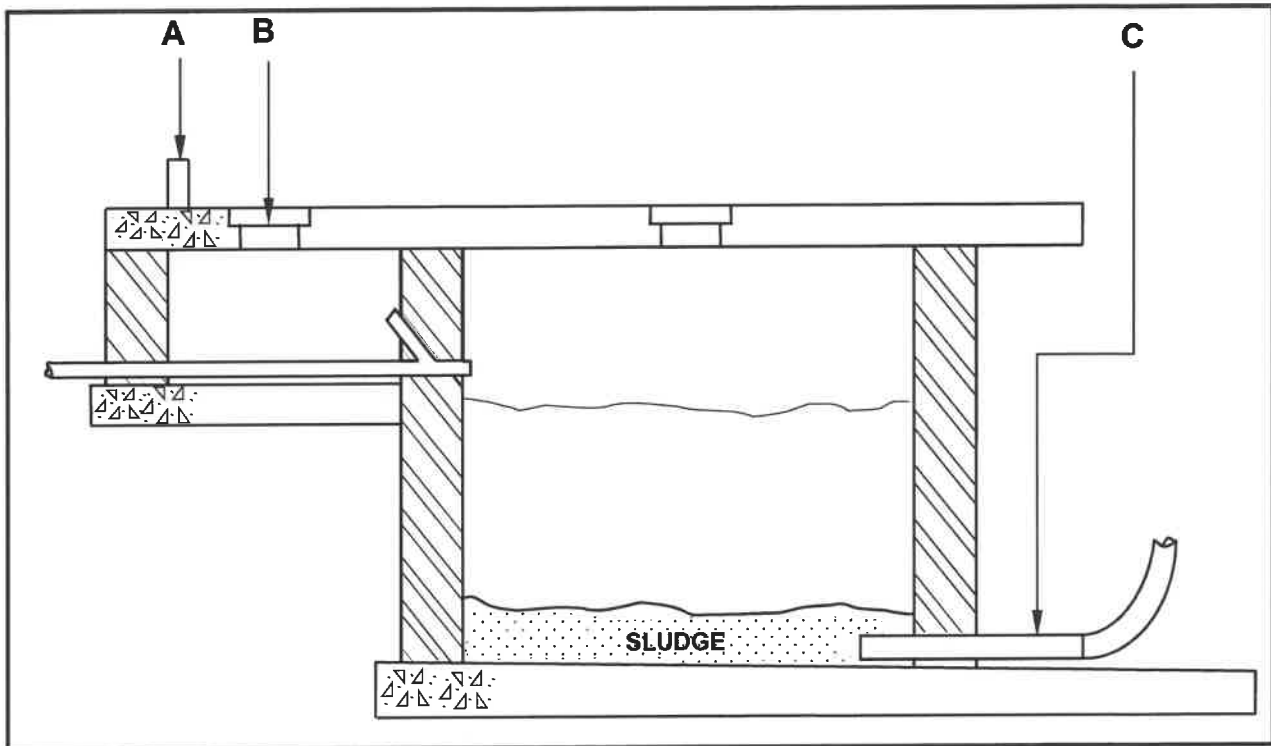

**FIGURE 6.7**

- 6.7.1 Identify the system above. (1)
  - 6.7.2 Identify parts **A** and part **B**. (2)
  - 6.7.3 Name the fixture that part **C** should be connected to in order to allow sewage to be removed. (1)
  - 6.8 ANSWER SHEET 6.8 shows the floor plan of a dwelling and an outbuilding with an incomplete sewerage system. (16)
- Use ANSWER SHEET 6.8 to design and draw the sewerage layout for the dwelling and outbuilding. [40]

**TOTAL: 200**



CENTRE NUMBER: EXAMINATION NUMBER: **ANSWER SHEET 2**

NO.	QUESTIONS	ANSWERS	MARKS
1.	What elevation is indicated by FIGURE A?		1
2.	Deduce, from the notes column, what type of roof is indicated by number 1.		1
3.	What energy-generating components are installed on the roof, as indicated by number 2?		1
4.	Identify number 3.		1
5.	Identify number 4.		1
6.	What material is recommended to be used to manufacture number 5?		1
7.	Identify number 6.		1
8.	Write down the abbreviation for number 7.		1
9.	Identify the end shape used to manufacture number 8.		1
10.	How many built-in cupboards are there in the building?		1
11.	What electrical installation has been omitted in the building?		1
12.	What type of material can be used to manufacture the fascia board in FIGURE A?		1
13.	How should the opening direction of the sliding door be indicated on the floor plan?		1
14.	Name ONE material that can be used to manufacture number 9.		1
15.	Deduce, from the notes column, what must be installed above every window.		1

**CENTRE NUMBER:**

**EXAMINATION NUMBER:**

16.	How many external doors are visible on the southern side of the building?		1
17.	How many water closets are installed in the building?		1
18.	Identify number 10.		1
19.	Deduce the thickness of the internal walls from FIGURE B.		1
20.	State the reference code of the proposed building.		1
21.	How many 1 200 x 600 mm windows are there in the building?		1
22.	Deduce, from the notes column, the dimensions of the aluminium side panel with windows.		2
23.	Draw the symbol for a grease trap.		3
24.	Draw the symbol for undisturbed earth.		3
25.	What sanitary fitting is installed in the scullery?		1
26.	Calculate the area of the scullery to be covered with floor tiles. The sink unit must be installed on top of the tiles. Give your answer in m <sup>2</sup> .		3
27.	Calculate the total length of the wall on the northern side of the building. Show ALL calculations. The length must be indicated in metres.		7
		<b>TOTAL:</b>	<b>40</b>

**CENTRE NUMBER:**

**EXAMINATION NUMBER:**

**ANSWER SHEET 3.4**

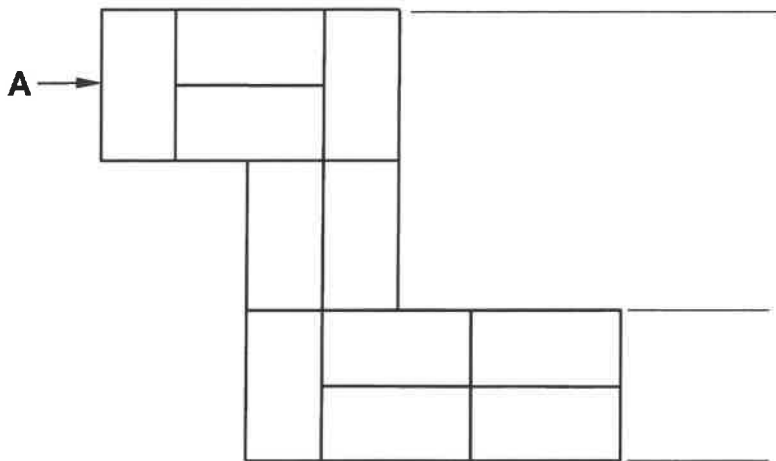

**FIGURE 3.4**

<b>ASSESSMENT CRITERIA</b>		
<b>NO.</b>	<b>MARK</b>	<b>CANDIDATE'S MARK</b>
1	3	
2	3	
3	2	
<b>TOTAL:</b>	<b>8</b>	

**CENTRE NUMBER:**

**EXAMINATION NUMBER:**

**ANSWER SHEET 5.4**

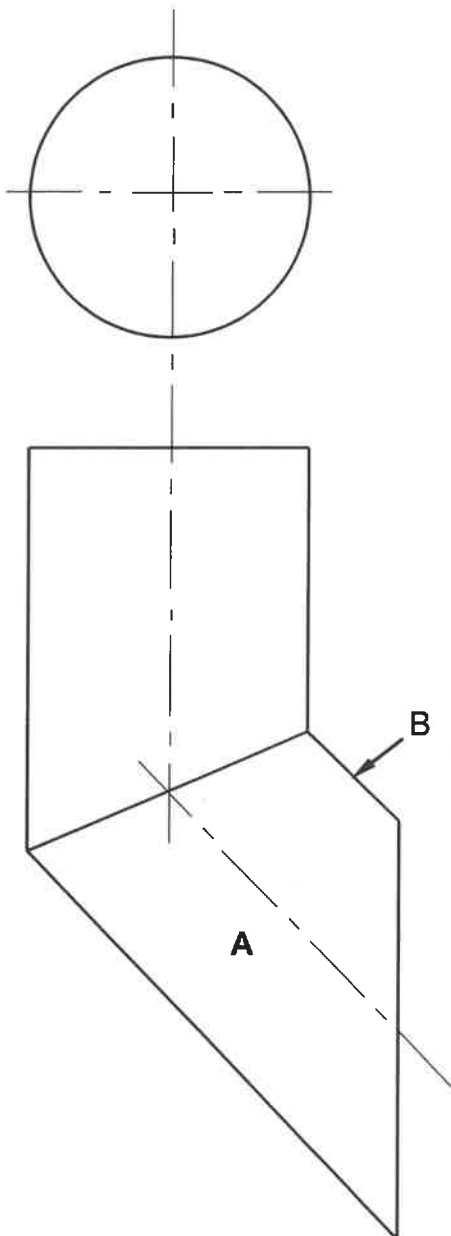

ASSESSMENT CRITERIA		
NO.	MARK	CANDIDATE'S MARK
1	1	
2	2	
3	2	
4	6	
5	6	
6	2	
<b>TOTAL:</b>	<b>19</b>	

**CENTRE NUMBER:**

**EXAMINATION NUMBER:**

**ANSWER SHEET 6.8**

MUNICIPAL CONNECTION

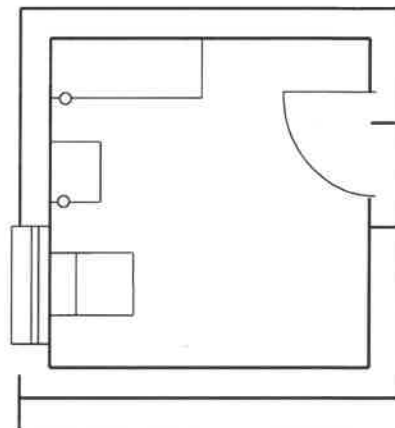
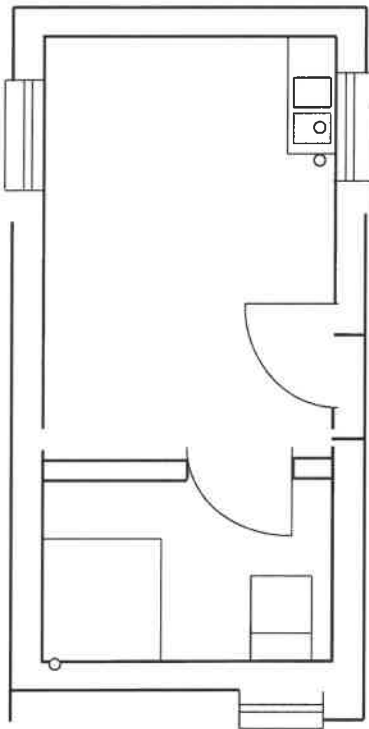

ASSESSMENT CRITERIA		
NO.	MARK	CANDIDATE'S MARK
1	4	
2	4	
3	2	
4	1	
5	2	
6	1	
7	2	
<b>TOTAL:</b>	<b>16</b>	