



# basic education

---

Department:  
Basic Education  
**REPUBLIC OF SOUTH AFRICA**

**NATIONAL  
SENIOR CERTIFICATE**

**GRADE 12**

**CIVIL TECHNOLOGY: CIVIL SERVICES**

**NOVEMBER 2025**

**MARKING GUIDELINES**

**MARKS: 200**

**These marking guidelines consist of 18 pages.**

## INSTRUCTIONS FOR MARKERS

### 1. Markers should:

- Familiarise themselves with the question and answer before evaluating the responses of candidates.
- Always interpret the responses of the candidates within the context of the question.
- Consider any relevant and acceptable answer during pre-marking but should strictly adhere to the answers after finalisation of the marking guideline.
- There are TWO approaches to answering describe and explain type of questions.
  1. If a candidate is required to explain e.g., a process in a prescribed number of steps (e.g. 3 steps), only the first required number of responses should be considered.
  2. However, if for example candidate is required to explain or describe a process, we need to consider that candidates may write a long description, not necessarily well organised. In this case the marker needs to evaluate the complete statement to judge if the candidate explained the required outcome satisfactorily and allocate marks on merit.

Answering short questions.

1. **Bullet Form Answers:** When a candidate provides their answers in bulleted points, each bullet should be treated as a single answer. Award 1 mark for each complete bulleted response.
  2. **Paragraph Form Answers:** When a candidate provides answers in paragraph form, the response should be evaluated based on the accuracy and completeness of each fact presented. Award marks for each distinct fact or point made, ensuring that each fact is correctly articulated.
- Mark what the candidate wrote and do not interpret or predict responses.
  - Indicate the tick or cross right at the position where the mark needs to be awarded or where the candidate made the error.
  - Accept the letter corresponding with the correct answer as well as the answer written in full in multiple-choice questions or similar questions.
  - Accept incorrect spelling in answers unless the spelling changes the meaning of the answer.
  - If a learner writes two or more answers separated by a slash (/) mark only the first response, unless the additional answer/s are different names for the same item, e.g. Yale lock/Night latch. In this case, the answer for the response should be awarded and the slash (/) should NOT be considered as an additional answer.

**2. For calculations:**

- A mark is only awarded if the correct unit is written next to the answer. If the question states that the answer must be in a specific unit, a mark will be awarded even if the answer is indicated without the unit.
- Marks will only be allocated for the correct values if the candidates add instead of multiply. NO marks will be awarded for the calculations and the answer.
- Where an incorrect answer is correctly carried over, the marker must recalculate the values, using the incorrect answer from the first calculation. If correctly used, the candidate should receive the full marks for subsequent calculations.
- Alternative methods of calculations must be considered, provided that the correct answer is obtained.
- For the calculation of quantities marks will be awarded for the correct use of the dimension paper.

**3. When marking drawings:**

- The member for which the mark should be awarded should be drawn correctly in the correct position to receive a mark.
- A member incorrectly drawn but wrongfully repeated in another position will be awarded the mark for the repeated incorrect member provided that the marking guideline provides for TWO or more marks for that member (positive marking).
- Marks can only be awarded for a label if the label is correctly indicating the correct member. Do not consider labels for members of which the labels were provided on the answer sheet.
- Scale drawings should always be marked using an appropriate mask.
- If the incorrect/wrong drawing was drawn, the candidate can be awarded for only what was provided for on the marking guideline.
- If a line diagram or an orthographic view instead of a pictorial drawing (isometric/oblique/perspective) is drawn, the first assessment criteria for each member will be marked wrong, but marks will be awarded for the subsequent members if TWO or more marks are awarded for the same member.
- If candidates draw/give more information than what is required, mark strictly according to the assessment criteria. However, if the additional information alters or contradicts the correct response, the answer should be marked as incorrect.

**4. Incorrect numbering of questions:**

- If a candidate numbered incorrectly, but the answer is in the correct position according to the sequence of the questions in the question paper, circle the incorrect numbering and mark the response.
- If questions were answered randomly not following the same sequence as in the question paper and the learner numbered incorrectly, the response should NOT be marked.

**5. Duplication of responses and questions answered in the correct place:**

- If a question is answered twice, mark the first response.
- If a question should be answered on an answer sheet and the candidate answered it on both the answer sheet and in the answer book, mark the response on the answer sheet and cancel the response in the answer book.

- If the question was answered in the answer book instead of on the answer sheet, mark the response in the answer book according to the assessment criteria on the marking guideline.

**QUESTION 1: OHSA, MATERIALS, TOOLS, EQUIPMENT AND JOINING (GENERIC)**

- |     |  |  |     |
|-----|--|--|-----|
| 1.1 | 1.1.1  | 38 mm ✓  | (1) |
|     | 1.1.2  | 150 mm ✓   | (1) |
|     | 1.1.3  | 320 kg per m <sup>2</sup> ✓  | (1) |
|     | 1.1.4  | two ✓  | (1) |
|     | 1.1.5  | two ✓  | (1) |
|     | 1.1.6  | overhead ✓   | (1) |
|     | 1.1.7  | two thirds ✓   | (1) |
|     | 1.1.8  | unauthorised persons ✓   | (1) |
|     | 1.1.9  | 760 x 560 mm ✓   | (1) |
|     | 1.1.10   | health and safety ✓  | (1) |
| 1.2 | C ✓  |  | (1) |
| 1.3 | Bolts are purchased according to: <ul style="list-style-type: none"><li>• Length of the shank ✓</li><li>• Diameter ✓</li><li>• Type of thread</li><li>• Head size</li><li>• Type of head</li><li>• Strength</li><li>• Material</li></ul> <b>ANY TWO OF THE ABOVE</b> |  | (2) |
| 1.4 | 1.4.1  | Process of powder coating:<br>Applying a plastic finish/coating in powder form, ✓ by using a spray gun ✓ | (2) |

## 1.4.2 Advantages of applying powder coating to a metal:

- Strengthen the metal ✓
- Provides stability
- Environmentally friendly
- Thicker coat can be applied
- More durable
- Available in a variety of colours, textures and gloss levels
- Withstand higher levels of heat
- Thermoset powder coatings have a beautiful appearance
- It is cheaper than other methods
- Resists corrosion

**ANY ONE OF THE ABOVE**

(1)

## 1.5 Do not use the following to clean a multi detector:

- Cleaning agents ✓
- Solvents/Chemicals
- Moist cloth

**ANY ONE OF THE ABOVE**

(1)

## 1.6 Two materials that can be detected:

- Steel ✓
- Copper ✓
- Brass
- Wiring/AC

**ANY TWO OF THE ABOVE**

(2)

## 1.7 Plumb bob ✓

(1)

**[20]**

**QUESTION 2: GRAPHICS AS MEANS OF COMMUNICATION (GENERIC)**

NO.	QUESTIONS	ANSWERS	MARKS
1.	What elevation is indicated by FIGURE A?	West elevation/West/W ✓	1
2.	Deduce, from the notes column, what type of roof is indicated by number 1.	Hipped roof ✓	1
3.	What energy-generating components are installed on the roof, as indicated by number 2?	Solar Panels ✓	1
4.	Identify number 3.	Fascia board ✓	1
5.	Identify number 4.	Window sill/Sill ✓	1
6.	What material is recommended to be used to manufacture number 5?	Stainless steel ✓	1
7.	Identify number 6.	NGL/Natural ground level ✓	1
8.	Write down the abbreviation for number 7.	FFL ✓	1
9.	Identify the end shape used to manufacture number 8.	Round/Square/Rectangular ✓	1
10.	How many built-in cupboards are there in the building?	One/1 ✓	1
11.	What electrical installation has been omitted in the building?	Socket outlet/Switch socket outlet/Lights/Electrical wiring/ Switch/Distribution board/ Inverter ✓	1
12.	What type of material can be used to manufacture the fascia board in FIGURE A?	Timber/Fibre cement/ uPVC/Aluminium/Stainless steel/Galvanised sheets ✓	1
13.	How should the opening direction of the sliding door be indicated on the floor plan?	By means of an arrow ✓	1
14.	Name ONE material that can be used to manufacture number 9.	Ceramic/PVC/Timber/Steel/ Stainless steel/Porcelain/Clay/ Plastic/Fibre glass/Glass/Concrete/ Stone/Marble/Terrazzo/ Cast iron/Pressed steel/Brass ✓	1

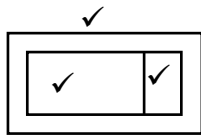
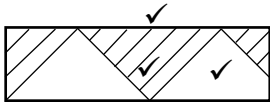
15.	Deduce, from the notes column, what must be installed above every window.	Lintels ✓	1
16.	How many external doors are visible on the southern side of the building?	Two/2 ✓	1
17.	How many water closets are installed in the building?	Four/4 ✓	1
18.	Identify number 10.	One-way switch double pole ✓	1
19.	Deduce the thickness of the internal walls from FIGURE B.	110 mm/110 ✓	1
20.	State the reference code of the proposed building.	QP 5 - 2025 ✓	1
21.	How many 1 200 x 600 mm windows are there in the building?	Five/5 ✓	1
22.	Deduce, from the notes column, the dimensions of the aluminium side panel with windows.	600 ✓ x 2 000 mm ✓	2
23.	Draw the symbol for a grease trap.		3
24.	Draw the symbol for undisturbed earth.		3
25.	What sanitary fitting is installed in the scullery?	Sink unit – double/Double sink ✓	1
26.	Calculate the area of the scullery to be covered with floor tiles. The sink unit must be installed on top of the tiles. Give your answer in m <sup>2</sup> .	5 ✓ x 4 ✓ = 20 ✓ m <sup>2</sup>  <b>OR</b> = 5 000 mm x 4 000 mm = 20 m <sup>2</sup>	3
27.	Calculate the total length of the wall on the northern side of the building. Show ALL calculations. The length must be indicated in metres.	220 ✓ + 5 000 ✓ + 110 ✓ + 5 000 ✓ + 220 ✓ = 10 550 ✓ mm = 10,55 ✓ m  <b>OR</b> 0,22 + 5 + 0,11 + 5 + 0,22 = 10,55 m	7
		<b>TOTAL:</b>	<b>40</b>

**QUESTION 3: CONSTRUCTION ASSOCIATED WITH CIVIL SERVICES, OHSA  
AND QUANTITIES (SPECIFIC)**

- 3.1      3.1.1      Faults in the manhole installation:
- The walls are not on the foundation ✓
  - The benching is not at a slope ✓
  - The channel is too shallow ✓
  - The channel needs to be half-round
  - No manhole cover/Cover lid omitted
  - No manhole cover frame
- ANY THREE OF THE ABOVE** (3)
- 3.1.2      Medical/First aid ✓ (1)
- 3.1.3      Breathing apparatus/Respirator/Gas mask ✓ (1)
- 3.1.4      A dust mask that covers the mouth and nose does not filter the air to protect a person from harmful gasses ✓/It will not provide sufficient protection where harmful gasses are present.  
**ANY ONE OF THE ABOVE** (1)
- 3.1.5      Stretcher bond/English bond ✓ (1)
- 3.1.6      Concrete ring manhole/Plastic/Fibre glass ✓ (1)

3.2

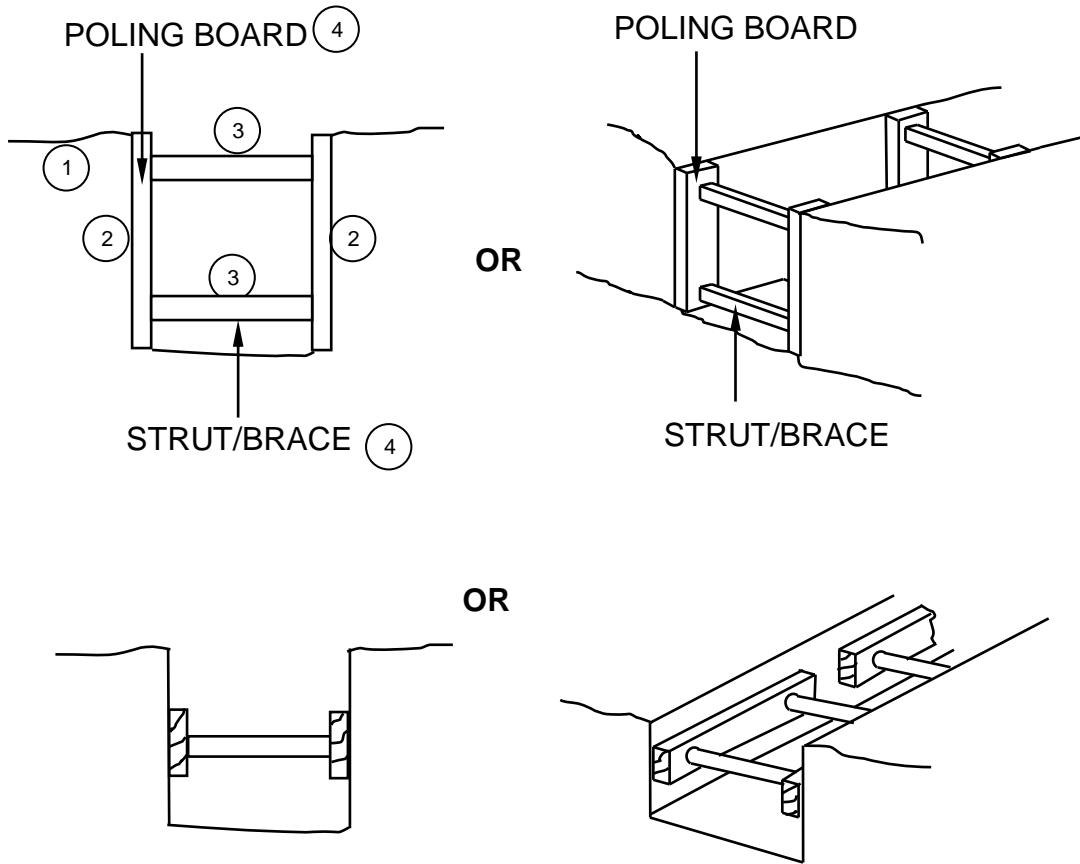

NO.	ASSESSMENT CRITERIA	MARK
1	Excavation/Trench	1
2	Poling boards	2
3	Struts/Braces	2
5	Any TWO labels	2
<b>TOTAL:</b>		<b>7</b>

(7)

3.3 3.3.1 Volume of a cubic water storage tank:

$$\begin{aligned} \text{Volume} &= l \times b \times h \\ \text{Volume} &= s^3 \\ &= 2,65 \checkmark \text{ m} \times 2,65 \checkmark \text{ m} \times 2,65 \checkmark \text{ m} \\ &= 18,61 \checkmark \text{ m}^3 \end{aligned}$$

**OR**

$$\begin{aligned} &2\ 650 \times 2\ 650 \times 2\ 650 \\ &= 18\ 609\ 625\ 000 \\ &= 18,61 \text{ m}^3 \end{aligned}$$

(4)

3.3.2 Volume of water in tank =  $18,61 \checkmark \times 1\ 000 \checkmark$   
=  $18\ 610 \text{ l} \checkmark$

(3)

3.4

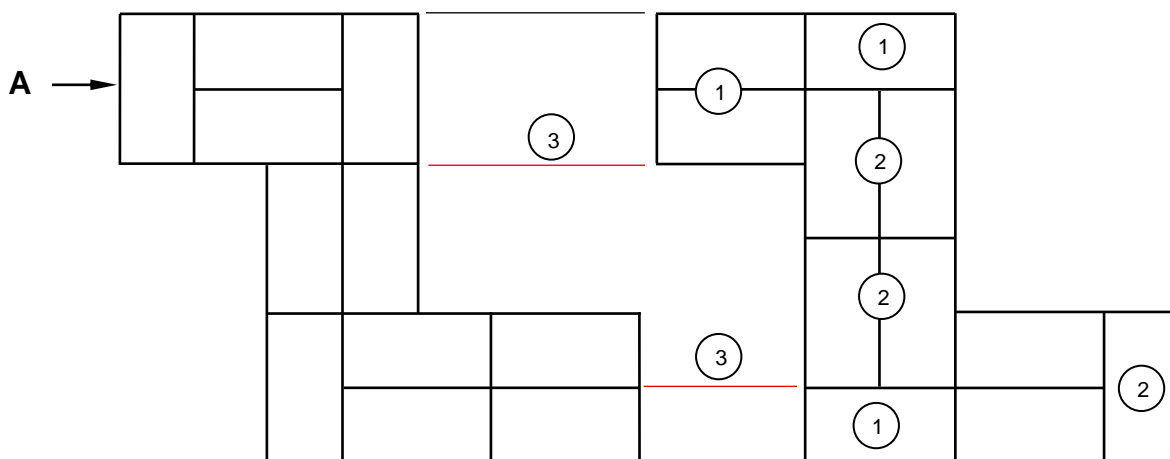



NO.	ASSESSMENT CRITERIA	MARK
1	Horizontal bricks	3
2	Vertical bricks	3
3	Projection lines	2
<b>TOTAL:</b>		<b>8</b>

(8)  
[30]

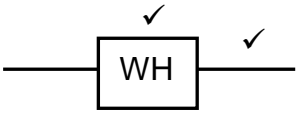
**QUESTION 4: COLD AND HOT-WATER SUPPLY, TOOLS, EQUIPMENT AND MATERIALS (SPECIFIC)**

- 4.1 4.1.1 E ✓
- 4.1.2 B ✓
- 4.1.3 D ✓
- 4.1.4 C ✓
- 4.1.5 G ✓
- 4.1.6 I ✓
- 4.1.7 K ✓
- 4.1.8 H ✓ (8)
- 4.2 4.2.1 A – Pressure-reducing valve/Pressure control valve ✓  
B – Vacuum breaker ✓  
C – TP safety valve/Outlet/Pipe ✓  
D – Drain cock ✓ (4)
- 4.2.2 When hot water heats up it rise to the top of the cylinder. ✓ (1)
- 4.2.3 300 mm ✓ (1)
- 4.2.4 If a leakage occurs water may damage the ceiling and anything below the ceiling. ✓ (1)
- 4.2.5 Ø 50 mm ✓ (1)
- 4.2.6 A – Reduces and controls the incoming water pressure to the geyser. ✓  
D – Is used to drain the geyser when repairs need to be done or when the geyser needs to be replaced. ✓ (2)
- 4.2.7  (2)
- 4.3 Uses of water-pressure testing pump:  
• To test the water pressure in pipes ✓ (1)
- Centrifugal pump:  
• To pump water from one place to another ✓  
• To increase the water pressure
- ANY ONE OF THE ABOVE** (1)

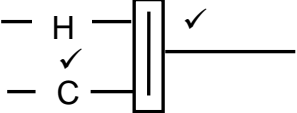
- 4.4 4.4.1  (2)
- 4.4.2  (2)
- 4.4.3  (2)
- 4.5 4.5.1 If water is not hot enough it may be:
  - that the thermostat is set too low ✓
  - that the thermostat and element is malfunctioning
  - that there is an insufficient electricity supply**ANY ONE OF THE ABOVE** (1)
- 4.5.2 Preventing the shortage of hot water:
  - Set thermostat to 65° ✓/The required temperature
  - Ensure that the thermostat and element is in good working Condition ✓
  - Provide additional insulation to geyser and pipes
  - Ensure that the electricity supply to the geyser is switched on for a sufficient period of time**ANY TWO OF THE ABOVE** (2)
- 4.6 4.6.1 Waste bend plain 90° ✓ (1)
- 4.6.2 The function of the fitting is:
  - To connect two pipes of the same diameter at an angle of 90° ✓
  - To connect wastewater pipes at an angle
  - To change the direction of wastewater**ANY ONE OF THE ABOVE** (1)
- 4.6.3 The ends of the fitting are larger:
  - To ensure that the pipe fits in the fitting ✓
  - For joining purposes**ANY ONE OF THE ABOVE** (1)
- 4.6.4 Ø 40/50 mm ✓ (1)
- 4.7 The electrolytic reaction can be prevented:
  - By using the same type of metal throughout the whole system ✓
  - By using a non-metal coupling when copper pipe and galvanized pipes are connected ✓ (2)

- 4.8.1 Water saving valves in terms of use:
- A – This tap can be opened halfway to save water ✓
- OR**
- A strainer in the outlet of this tap can mix air with the water to reduce water usage (1)
- B – This tap allows water to flow as long as the button is pressed ✓
- OR**
- Water flows for a pre-set period when the button is pressed and saves water (1)
- 4.8.2 Electronic tap with sensor/Sensor tap/Electronic tap ✓ (1)
- [40]**



5.4

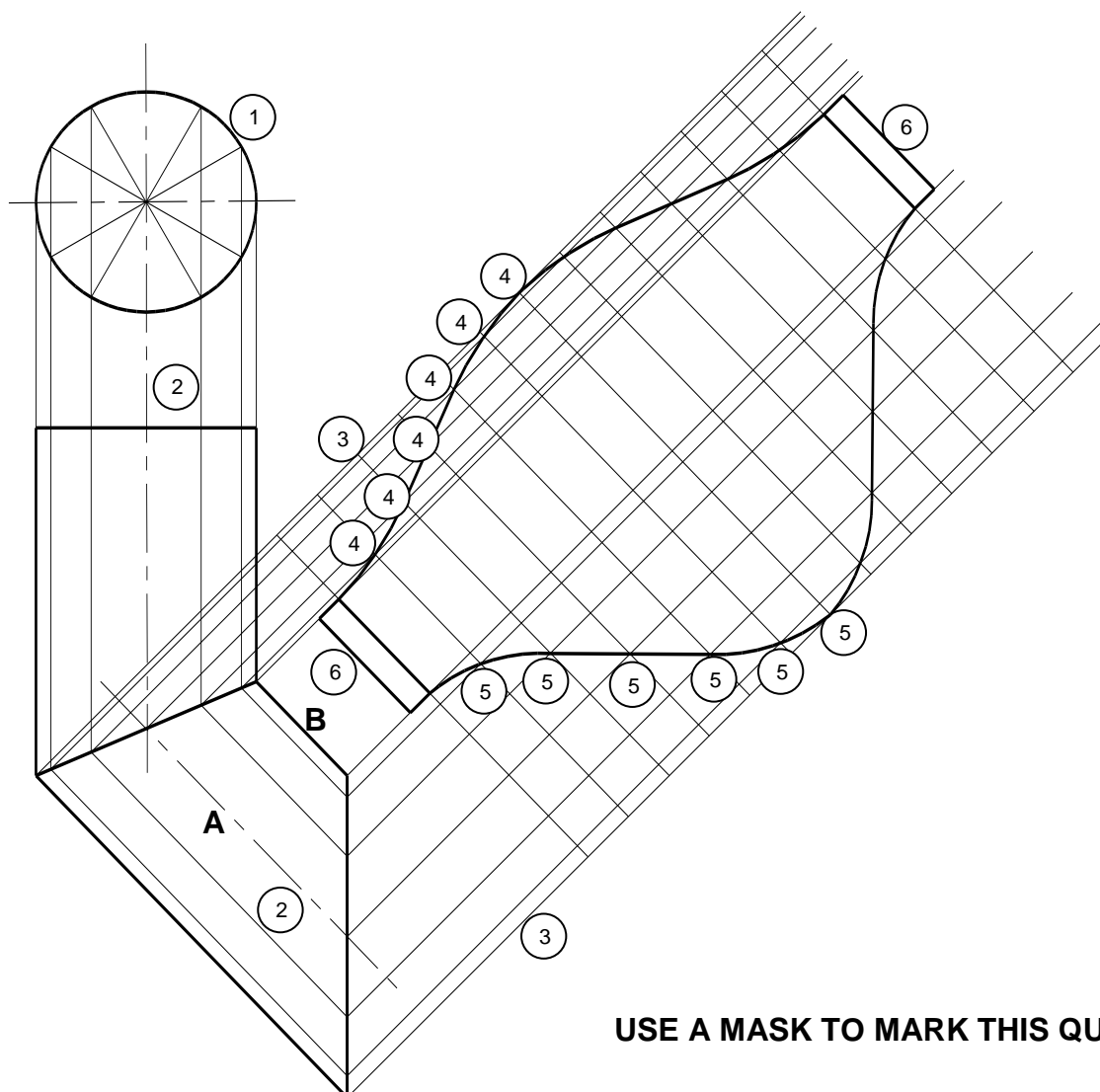

**USE A MASK TO MARK THIS QUESTION**

NO.	ASSESSMENT CRITERIA	MARK
1	Division of circle into 12 parts	1
2	Projection lines from circle	2
3	Projection lines from shoe	2
4	Development of base of shoe	6
5	Development of top of shoe	6
6	3 mm seams	2
<b>TOTAL:</b>		<b>19</b>

(19)  
[30]

**QUESTION 6: SEWERAGE, SANITARY FITTINGS AND JOINING (SPECIFIC)**

- 6.1      6.1.1      sludge ✓ (1)
- 6.1.2      compost ✓ (1)
- 6.1.3      Bio-reactor ✓ (1)
- 6.1.4      biomass ✓ (1)
- 6.1.5      chlorine ✓ (1)
- 6.2      6.2.1      90° elbow ✓ (1)
- 6.2.2      The rubber washer will prevent leaking/Seal the outlet ✓ (1)
- 6.2.3      PVC bend with inspection eye/PVC access bend ✓ (1)
- 6.2.4      • PVC weld ✓  
                    • Solvent weld  
                    • PVC glue/adhesive  
            **ANY ONE OF THE ABOVE** (1)
- 6.2.5      Prevents odours/sewer gas ✓from entering the dwelling. ✓ (2)
- 6.2.6      Gully ✓ (1)
- 6.3      6.3.1      Manhole/Rodding eye ✓ (1)
- 6.3.2      One/1 ✓ (1)
- 6.4      Materials that can be used for drainpipes:  
            • uPVC/Unplasticised Polyvinyl chloride ✓  
            • PVC/Polyvinyl chloride ✓  
            • Cast iron  
            • Fibre cement  
            • Clay or earthenware  
            • Concrete  
            **ANY TWO OF THE ABOVE** (2)

- 6.5 Properties of solder:
- Silver-coloured ✓
  - Heavy ✓
  - The higher the tin content, the higher the melting point
  - The higher the lead content, the lower the melting point
  - Can creep/Capillary action in liquid form
  - Elastic modulus
  - Elongation is possible
  - Ductile
  - High strain rate
  - Malleable
- ANY TWO OF THE ABOVE** (2)
- 6.6 If the head is too cold, the solder will not melt sufficiently to obtain proper adhesion. ✓  
If the head is too hot, the tin in the solder will burn, leaving it useless. ✓ (2)
- 6.7 6.7.1 Vacuum tank/Conservancy tank ✓ (1)
- 6.7.2 A – Vent pipe/Vent valve ✓  
B – Manhole cover/Lid ✓ (2)
- 6.7.3 Draw-off valve ✓ (1)

6.8

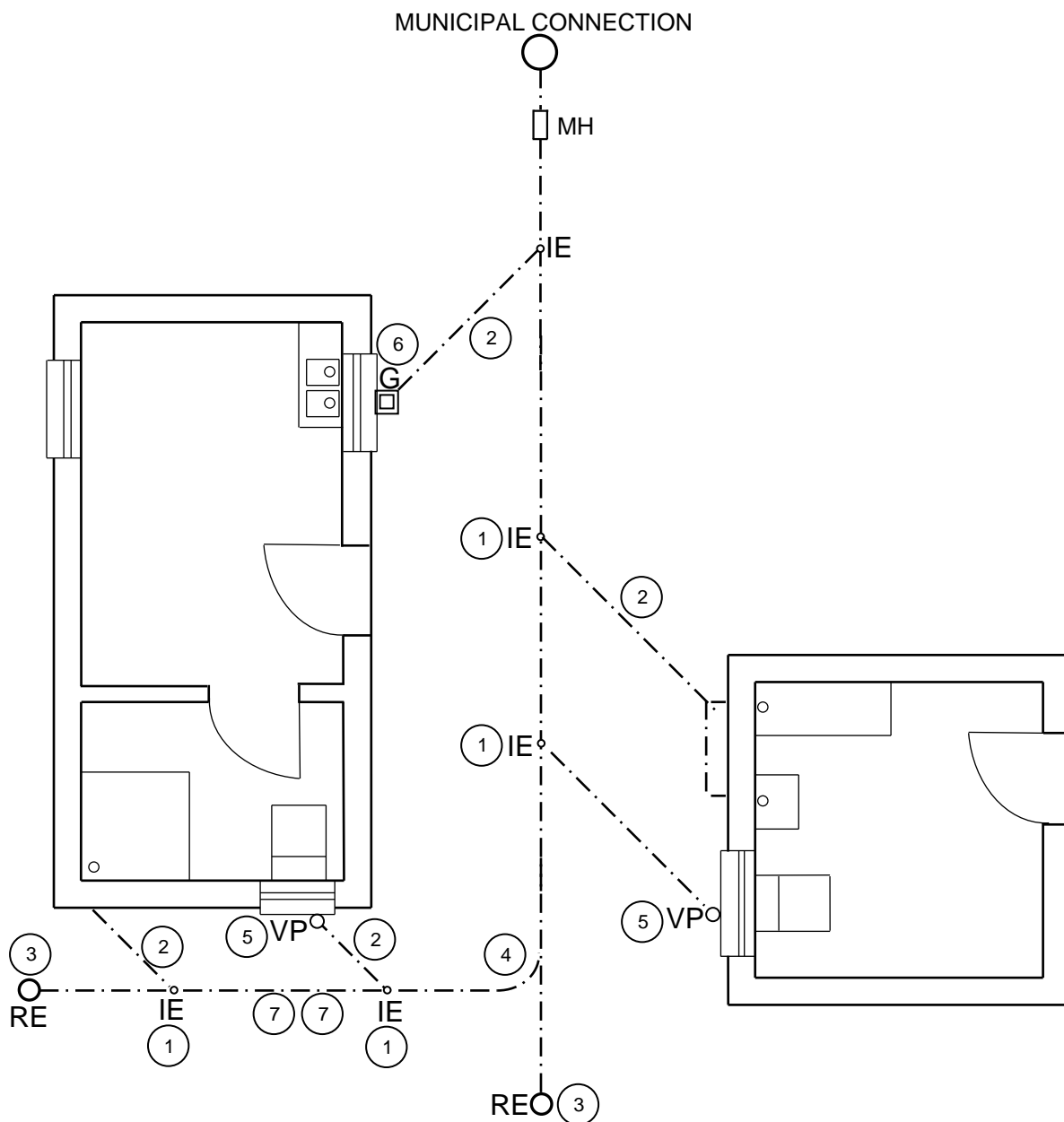

NO.	ASSESSMENT CRITERIA	MARK
1	Inspection eyes (Any FOUR)	4
2	Branch pipes (Any FOUR)	4
3	Rodding eyes	2
4	Junction of the main sewer pipes	1
5	Vent pipe (Correctly placed)	2
6	Gully	1
7	Main sewer line	2
<b>TOTAL:</b>		<b>16</b>

[40]

**TOTAL: 200**